

# Resistive Sensor Rotary Type

## RDC40/RDC50 Series



**RDC40** : Compatible with multi-rotational position tracking.

**RDC50** : Compact, high precision, high heat resistant rotary sensors meet various needs in position detection.

- Magnetic Sensors
- Piezo Sensors
- Capacitive Sensor
- Resistive Sensors**

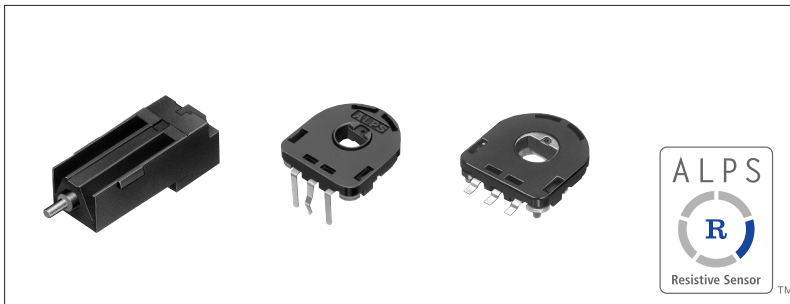

### Typical Specifications

Items	Specifications	
	RDC40	RDC50
Operating life	100,000cycles	1,000,000cycles
Total resistance	10kΩ	
Operating temperature range	-30°C to +80°C	-40°C to +120°C

### Product List

Mounting method	Effective variable range	Linearity	Hollow shaft variation	Operating life (cycles)	Minimum order unit (pcs.)	Model No.	Drawing No.
Connector type	13rotations	± 1%	—	100,000	770	RDC401D07A	1
Horizontal type	320°	± 2%	φ 3.5 dia	1,000,000	3,000	RDC501015A	2
			φ 3.5 dia with radius			RDC501011A	3
Vertical type			φ 3.5 dia		1,600	RDC502010A	4
Reflow type			φ 3.5 dia with radius		3,900	RDC503013A	5
			φ 3.5 dia with radius			RDC503015A	6
Reflow type (Low-profile)			φ 4 dia		3,600	RDC506002A	7

### Packing Specifications

Tray/Taping Unit:mm

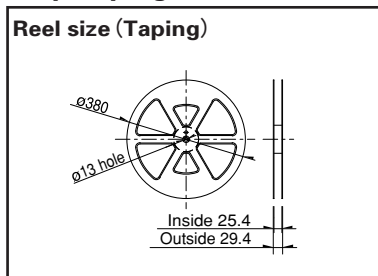

Series	Packing Specifications	Number of packages (pcs.)		Tape width (mm)	Export package measurements (mm)
		1 case /Japan	1 case /export packing		
RDC40	Tray	770	770	—	526 × 370 × 191
RDC501		1,500	3,000		
RDC502		1,600	1,600		370 × 280 × 92
RDC503	Taping	3,900	3,900	24	407 × 415 × 135
RDC506		3,600	3,600		

### Notes







1. Additional product specifications in response to those not included in the above recommended products are also available.
2. Please place purchase orders per minimum order unit N (integer).

Refer to **P.521** for product specifications.  
Refer to **P.522** for soldering conditions.

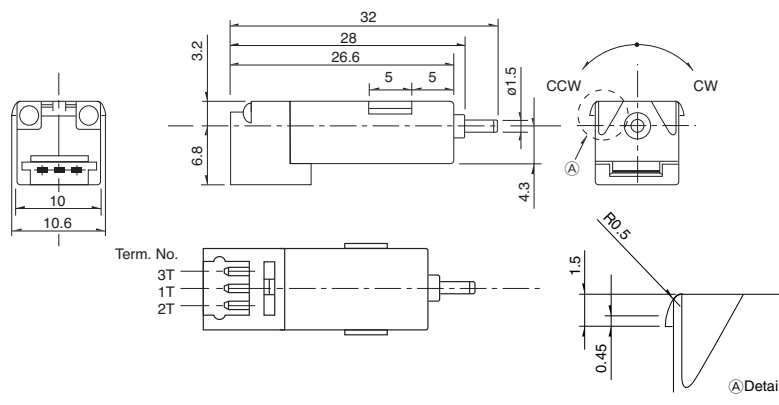

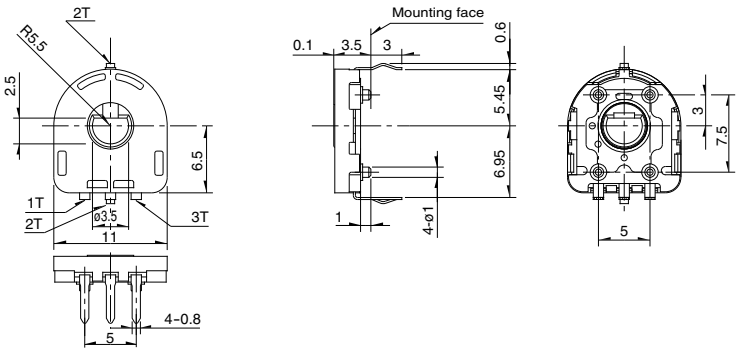
Dimensions

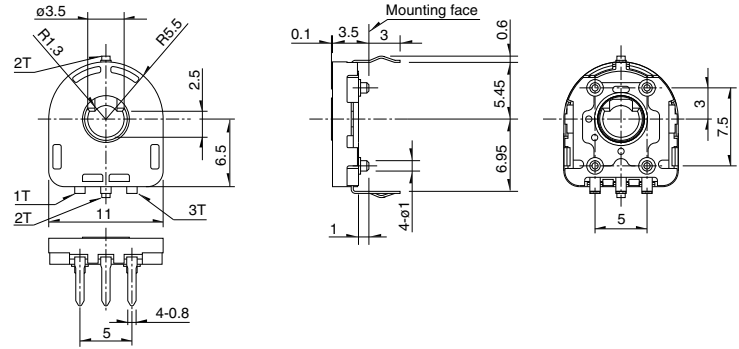
Unit:mm

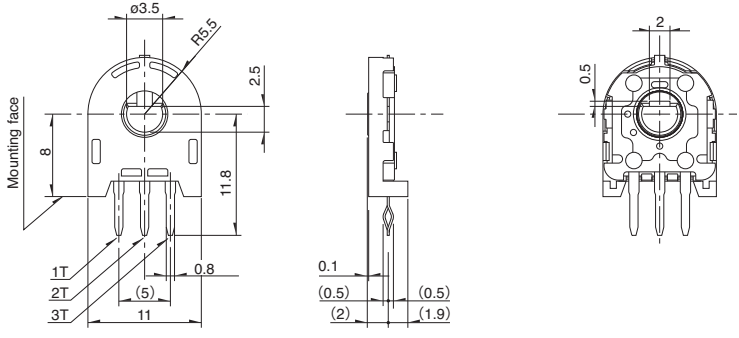
No.	Photo	Style
1	RDC40 (Multiple turns type) 	
2	RDC501 (Horizontal type) 	
3	RDC501 (Horizontal type, φ3.5 dia with radius) 	
4	RDC502 (Vertical type) 	





- Magnetic Sensors
- Piezo Sensors
- Capacitive Sensor
- Resistive Sensors**

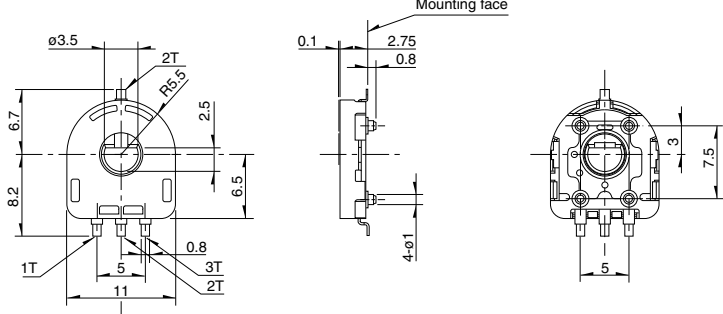

Dimensions

Unit:mm

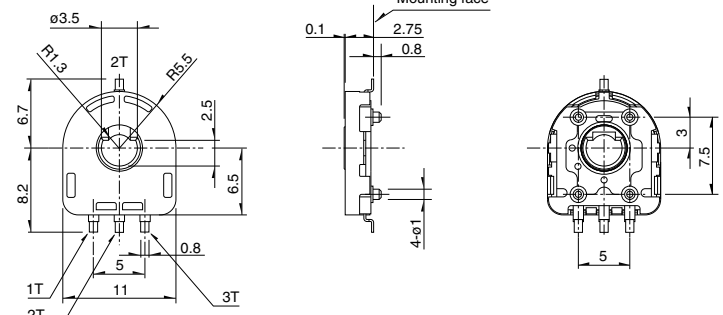

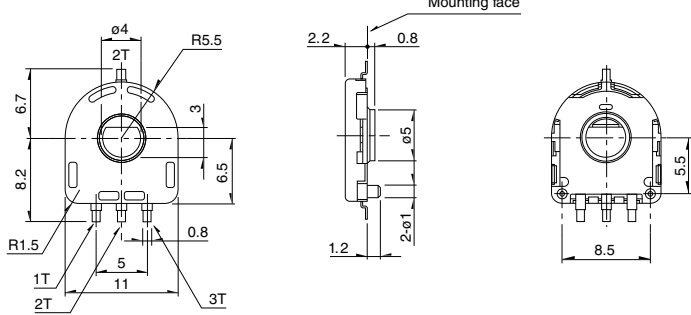

- Magnetic Sensors
- Piezo Sensors
- Capacitive Sensor
- Resistive Sensors**

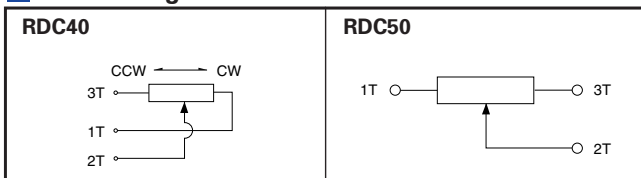
No.	Photo	Style
5		
6		
7		

Circuit Diagram

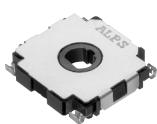

## Index for Functions

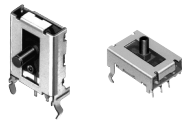
Type	Rotary Type			Linear Type		
Series	RDC40	RDC50	RDC80	RDC10	※RD7	
Photo						
Travel (mm)	_____			14mm (RDC1014) 22mm (RDC1022) 32mm (RDC1032) 47mm (RDC1047)	8mm (RD708) 9mm (RD709) 12mm (RD712)	
Mounting method	_____				Vertical   Horizontal	
Effective variable angle (°)	4680 (13 rotations)	320	330 (1-phase) 360 (2-phase)	_____		
Soldering	Manual soldering	_____				350°C max. 3s max.
	Dip soldering	_____	260°C, 4±1s	_____	_____	260°C, 4±1s
	Re-flow soldering	_____	Please see P.522		_____	_____
Operating temperature range	-30°C to +80°C	-40°C to +120°C		-30°C to +85°C	-40°C to +105°C	
Automotive use	●	●	●	●	●	
Mechanical performance	Operating force	_____			0.25N max.	2N max.
	Rotational torque	2mN·m max.		10mN·m max.	_____	
Electrical performance	Total resistance tolerance	±30%				±20%
	Linearity (%)	±1	±2	±3	±0.5	±1
	Rated Voltage (VDC)	5				12
Environmental test	Cold	-30±3°C for 240h	-40±3°C for 168h		-40±3°C for 240h	-40±3°C for 96h
	Dry heat	80±2°C for 240h	120±3°C for 168h		90±2°C for 240h	105±2°C for 96h
	Damp heat	60±2°C, 90 to 95%RH for 240h	60±2°C, 90 to 95%RH for 96h		60±2°C, 90 to 95%RH for 240h	40±2°C, 90 to 95%RH for 96h
Page	513		516	517	519	

Magnetic Sensors

Piezo Sensors

Capacitive Sensor

Resistive Sensors

- Resistive Sensors Product Specifications .....521
- Resistive Sensors Soldering Conditions .....522
- Resistive Sensors Measurement and Test Methods .....522
- Resistive Sensors Caution .....523

**Note**

1. ※The RD7 series are used to detect vehicle headlight angles.
2. ●marks in "Available for automotive use" indicate that all of the series products can work at the operating temperature range from -40°C to +85°C.

## Product Specifications

### Method for Regulating the Linearity

- Magnetic Sensors
- Piezo Sensors
- Capacitive Sensor
- Resistive Sensors**

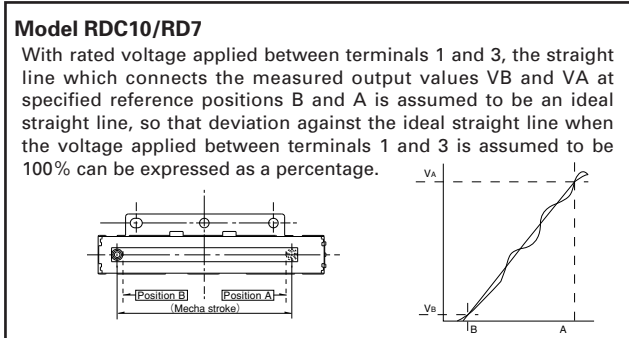
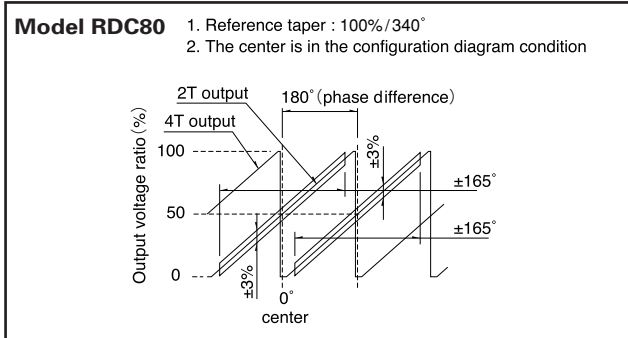
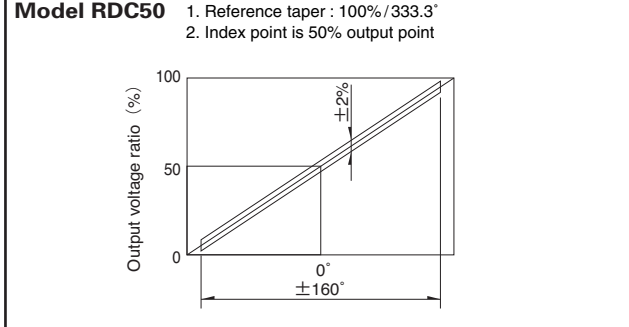
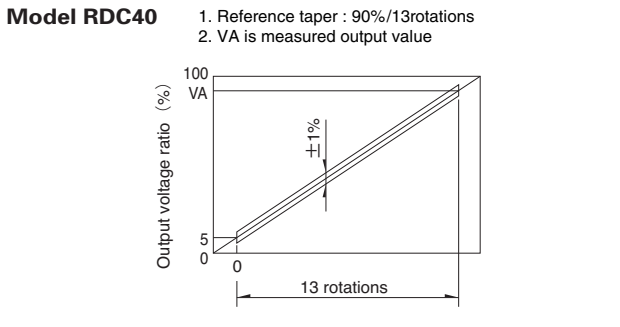

## Soldering Conditions

### Soldering Conditions

#### 1. Recommended reflow conditions

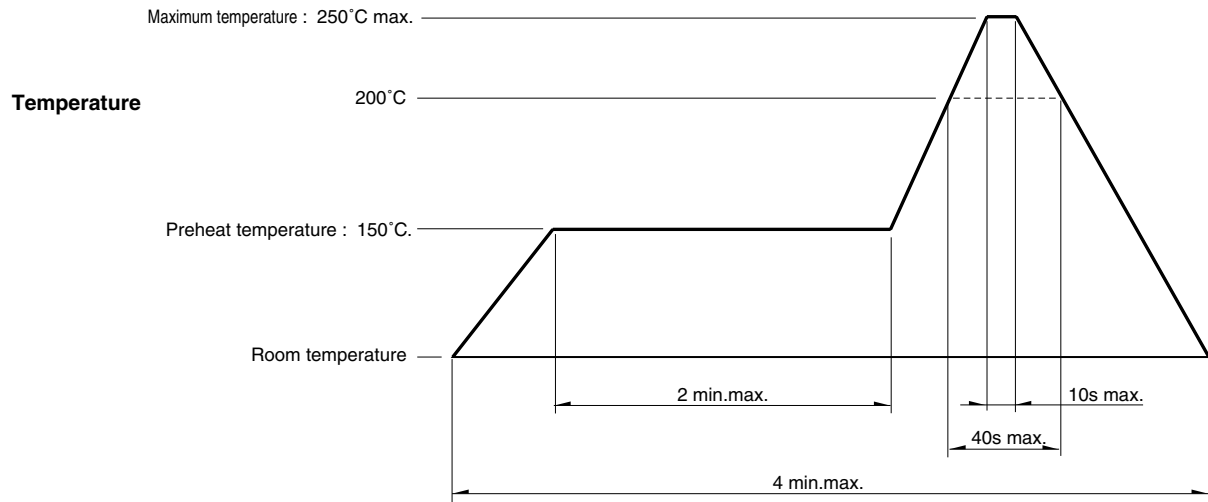

Magnetic Sensors

Piezo Sensors

Capacitive Sensor

Resistive Sensors

2. Cleaning Cleaning should not be attempted.
3. Type of solder to be used Use cream solder that contains 10 - 15 %wt flux.
4. Number of solder applications - apply solder only once

### Notes

1. When using an infrared reflow oven, solder may not always be applied as intended. Be sure to use a hot air reflow oven or a type that uses infrared rays in combination with hot air.
2. The temperatures given above are the maximum temperatures at the terminals of the potentiometer when employing a hot air reflow method. The temperature of the PC board and the surface temperature of the potentiometer may vary greatly depending on the PC board material, its size and thickness. Ensure that the surface temperature of the potentiometer does not rise to 250°C or greater.
3. Conditions vary to some extent depending on the type of reflow bath used. Be sure to give due consideration to this prior to use.

## Measurement and Test Methods

### Analog Output Contact Type Sensor

#### [Total Resistance]

The total resistance, with the shaft (lever) placed at the end of terminal 1 or 3, shall be determined by measuring the resistance between the resistor terminals 1 and 3 unless otherwise specified.

#### [Rating Voltage]

The rating voltage corresponding to the rated power shall be determined by the following equation. When the resulting rated voltage exceeds the maximum operating voltage of a specific resistor, the maximum operating voltage shall be taken as the rated voltage.

$E = \sqrt{P \cdot R}$
E : Rated voltage (V)
P : Rated power (W)
R : Total nominal resistance (Ω)