



晶采光電科技股份有限公司
AMPIRE CO., LTD.

SPECIFICATIONS FOR LCD MODULE

| | |
|--------------------------|----------------------------|
| CUSTOMER | |
| CUSTOMER PART NO. | |
| AMPIRE PART NO. | AM-320240LBTNQW-00H |
| APPROVED BY | |
| DATE | |

- Approved For Specifications
 Approved For Specifications & Sample

AMPIRE CO., LTD.

2F., No.88, Sec. 1, Sintai 5th Rd., Sijih City, Taipei County 221,
Taiwan (R.O.C.)台北縣汐止市新台五路一段88號2樓(東方科學園區D棟)
TEL:886-2-26967269 , FAX:886-2-26967196 or 26967270

| APPROVED BY | CHECKED BY | ORGANIZED BY |
|-------------|------------|--------------|
| | | |

RECORD OF REVISION

| Revision Date | Page | Contents | Editor |
|---------------|------|--------------------------------------------|--------|
| 2009/1/21 | -- | New Release | Edward |
| 2009/3/5 | -- | Rename to official P/N AM-320240LBTNQW-00H | Edward |

1 General Description and Features

3.5 inch Amorphous-TFT-LCD (Thin Film Transistor Liquid Crystal Display) module. This module is composed of a 3.5" TFT-LCD panel, a driver circuit and backlight unit.

- 1.1 Construction: 3.5" a-Si color TFT-LCD, White LED Backlight and PCB.
- 1.2 Resolution (pixel): 320(R.G.B) X240.
- 1.3 Number of the Colors: 262K colors (R, G, B 6 bit digital each).
- 1.4 LCD type: Transmissive Color TFT LCD (normally White) **with TMR polarizer.**
- 1.5 View Angle: 6 o'clock
- 1.6 18-Bit RGB Interface.
- 1.7 Interface: 40 pin.
- 1.8 Support SYNC Mode Only.
- 1.9 Power Supply Voltage: 3.3V single power input. Built-in power supply circuit.
- 1.10 LED Type Backlight and build-in LED Driver IC.

2 Physical specifications

| Item | Specifications | unit |
|---------------------|-----------------------------|------|
| Display Resolution | 320(W) x 240(H) | dot |
| Active area | 70.08 x 52.56 | mm |
| Screen size | 3.5(Diagonal) | inch |
| Dot pitch | 0.073 (W) x 0.219 (H) | mm |
| Color configuration | R.G.B – stripe | |
| Overall Dimension | 77.8(W) x 66.0(H) x 4.6(T) | mm |
| Input interface | digital 18-bits RGB | |
| Backlight unit | White LED | |
| Display Mode | Normally White/Transmissive | |

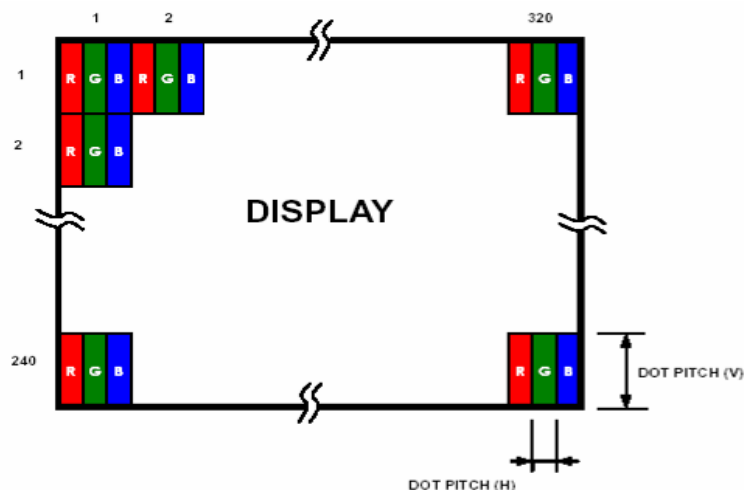

3 Functional Block Diagram

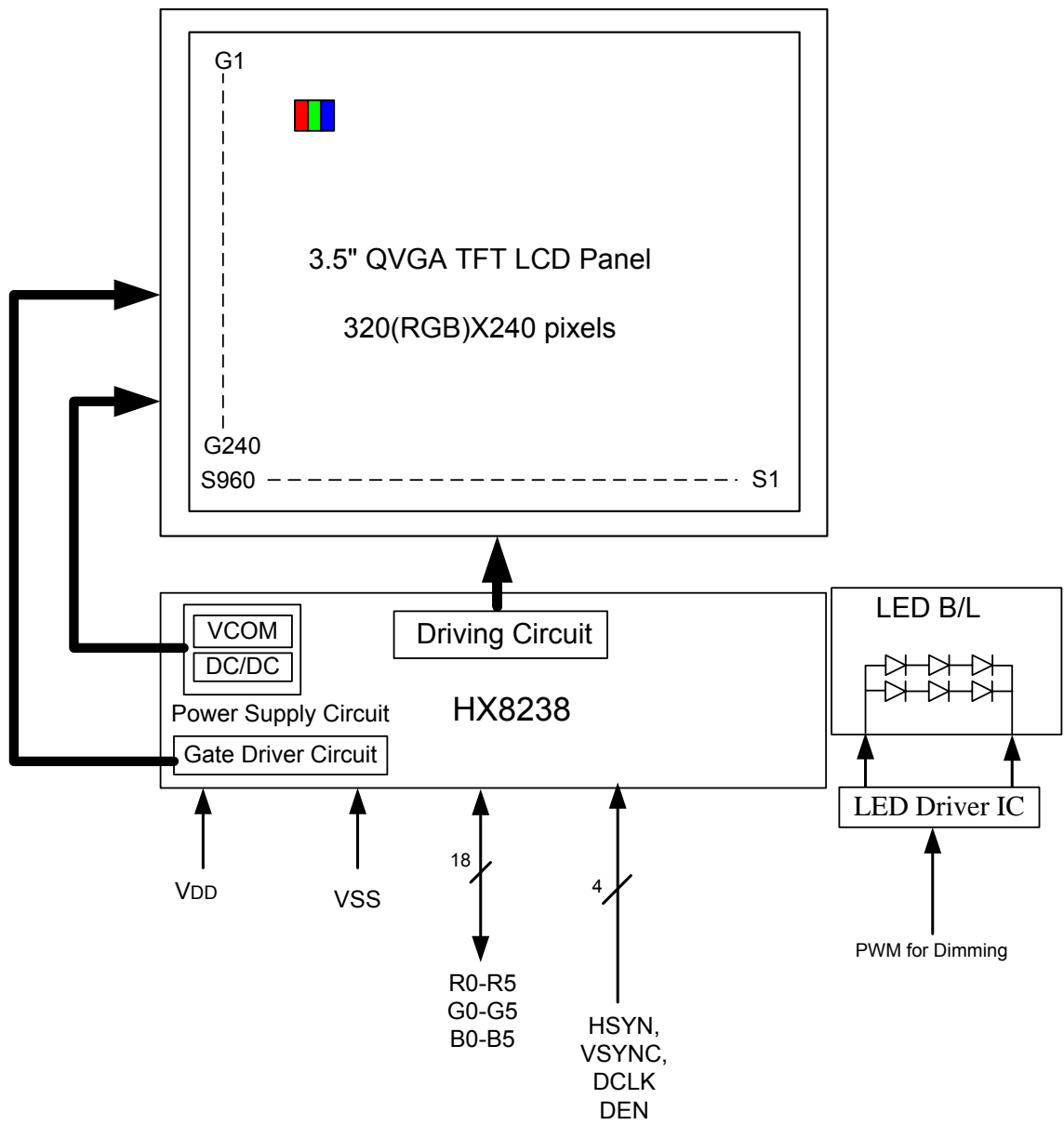

4 Electrical Specifications

TFT LCD Panel FPC Descriptions

| Pin no | Symbol | I/O | Description | Remark |
|--------|--------|-----|-------------------------------------------------|--------|
| 1~4 | VDD | | Power supply for the logic (3.3V) | |
| 5 | Hsync | I | Horizontal sync input in digital RGB mode | |
| 6 | DEN | | Keep this Pin NC. | |
| 7 | VSS | | GND | |
| 8 | DCLK | I | Clock signal. Latching data at the rising edge. | |
| 9 | VSS | | GND | |
| 10 | Vsync | I | Vertical sync input in digital RGB mode. | |
| 11 | VSS | | GND | |
| 12 | B5 | I | Blue data | |
| 13 | B4 | I | | |
| 14 | B3 | I | | |
| 15 | VSS | | GND | |
| 16 | B2 | I | Blue data | |
| 17 | B1 | I | | |
| 18 | B0 | I | | |
| 19 | VSS | | GND | |
| 20 | G5 | I | Green data | |
| 21 | G4 | I | | |
| 22 | G3 | I | | |
| 23 | VSS | | GND | |
| 24 | G2 | I | Green data | |
| 25 | G1 | I | | |
| 26 | G0 | I | | |
| 27 | VSS | | GND | |
| 28 | R5 | I | Red data | |
| 29 | R4 | I | | |
| 30 | R3 | I | | |
| 31 | VSS | | GND | |
| 32 | R2 | I | Red data | |
| 33 | R1 | I | | |
| 34 | R0 | I | | |
| 35 | PWM | I | For LED Driver IC Dimming; Keep Hi for LED ON. | |
| 36 | VSS | | GND | |
| 37 | NC | | No Connection | |
| 38 | NC | | No Connection | |
| 39 | NC | | No Connection | |
| 40 | NC | | No Connection | |

5 Basic Display Color and Gray Scale

| | Color & Gray Scale | DATA SIGNAL | | | | | | | | | | | | | | | | | |
|-------------|--------------------|-------------|----|----|----|----|----|----|----|----|----|----|----|----|----|----|----|----|----|
| | | R5 | R4 | R3 | R2 | R1 | R0 | G5 | G4 | G3 | G2 | G1 | G0 | B5 | B4 | B3 | B2 | B1 | B0 |
| Basic Color | Black | 0 | 0 | 0 | 0 | 0 | 0 | 0 | 0 | 0 | 0 | 0 | 0 | 0 | 0 | 0 | 0 | 0 | 0 |
| | Red(63) | 1 | 1 | 1 | 1 | 1 | 1 | 0 | 0 | 0 | 0 | 0 | 0 | 0 | 0 | 0 | 0 | 0 | 0 |
| | Green(63) | 0 | 0 | 0 | 0 | 0 | 0 | 0 | 1 | 1 | 1 | 1 | 1 | 1 | 0 | 0 | 0 | 0 | 0 |
| | Blue(63) | 0 | 0 | 0 | 0 | 0 | 0 | 0 | 0 | 0 | 0 | 0 | 0 | 0 | 1 | 1 | 1 | 1 | 1 |
| | Cyan | 0 | 0 | 0 | 0 | 0 | 0 | 1 | 1 | 1 | 1 | 1 | 1 | 1 | 1 | 1 | 1 | 1 | 1 |
| | Magenta | 1 | 1 | 1 | 1 | 1 | 1 | 0 | 0 | 0 | 0 | 0 | 0 | 0 | 1 | 1 | 1 | 1 | 1 |
| | Yellow | 1 | 1 | 1 | 1 | 1 | 1 | 1 | 1 | 1 | 1 | 1 | 1 | 0 | 0 | 0 | 0 | 0 | 0 |
| | White | 1 | 1 | 1 | 1 | 1 | 1 | 1 | 1 | 1 | 1 | 1 | 1 | 1 | 1 | 1 | 1 | 1 | 1 |
| Red | Black | 0 | 0 | 0 | 0 | 0 | 0 | 0 | 0 | 0 | 0 | 0 | 0 | 0 | 0 | 0 | 0 | 0 | 0 |
| | Red(1) | 0 | 0 | 0 | 0 | 0 | 1 | 0 | 0 | 0 | 0 | 0 | 0 | 0 | 0 | 0 | 0 | 0 | 0 |
| | Red(2) | 0 | 0 | 0 | 0 | 1 | 0 | 0 | 0 | 0 | 0 | 0 | 0 | 0 | 0 | 0 | 0 | 0 | 0 |
| | : | : | : | : | : | : | : | : | : | : | : | : | : | : | : | : | : | : | : |
| | Red(31) | 0 | 1 | 1 | 1 | 1 | 1 | 0 | 0 | 0 | 0 | 0 | 0 | 0 | 0 | 0 | 0 | 0 | 0 |
| | : | : | : | : | : | : | : | : | : | : | : | : | : | : | : | : | : | : | : |
| | Red(62) | 1 | 1 | 1 | 1 | 1 | 0 | 0 | 0 | 0 | 0 | 0 | 0 | 0 | 0 | 0 | 0 | 0 | 0 |
| | Red(63) | 1 | 1 | 1 | 1 | 1 | 1 | 0 | 0 | 0 | 0 | 0 | 0 | 0 | 0 | 0 | 0 | 0 | 0 |
| Green | Black | 0 | 0 | 0 | 0 | 0 | 0 | 0 | 0 | 0 | 0 | 0 | 0 | 0 | 0 | 0 | 0 | 0 | 0 |
| | Green(1) | 0 | 0 | 0 | 0 | 0 | 0 | 0 | 0 | 0 | 0 | 0 | 1 | 0 | 0 | 0 | 0 | 0 | 0 |
| | Green(2) | 0 | 0 | 0 | 0 | 0 | 0 | 0 | 0 | 0 | 0 | 1 | 0 | 0 | 0 | 0 | 0 | 0 | 0 |
| | : | : | : | : | : | : | : | : | : | : | : | : | : | : | : | : | : | : | : |
| | Green(31) | 0 | 0 | 0 | 0 | 0 | 0 | 0 | 1 | 1 | 1 | 1 | 0 | 0 | 0 | 0 | 0 | 0 | 0 |
| | : | : | : | : | : | : | : | : | : | : | : | : | : | : | : | : | : | : | : |
| | Green(62) | 0 | 0 | 0 | 0 | 0 | 0 | 1 | 1 | 1 | 1 | 1 | 0 | 0 | 0 | 0 | 0 | 0 | 0 |
| | Green(63) | 0 | 0 | 0 | 0 | 0 | 0 | 1 | 1 | 1 | 1 | 1 | 1 | 0 | 0 | 0 | 0 | 0 | 0 |
| Blue | Black | 0 | 0 | 0 | 0 | 0 | 0 | 0 | 0 | 0 | 0 | 0 | 0 | 0 | 0 | 0 | 0 | 0 | 0 |
| | Blue(1) | 0 | 0 | 0 | 0 | 0 | 0 | 0 | 0 | 0 | 0 | 0 | 0 | 0 | 0 | 0 | 0 | 0 | 1 |
| | Blue(2) | 0 | 0 | 0 | 0 | 0 | 0 | 0 | 0 | 0 | 0 | 0 | 0 | 0 | 0 | 0 | 0 | 0 | 1 |
| | : | : | : | : | : | : | : | : | : | : | : | : | : | : | : | : | : | : | : |
| | Blue(31) | 0 | 0 | 0 | 0 | 0 | 0 | 0 | 0 | 0 | 0 | 0 | 0 | 0 | 1 | 1 | 1 | 1 | 1 |
| | : | : | : | : | : | : | : | : | : | : | : | : | : | : | : | : | : | : | : |
| | Blue(62) | 0 | 0 | 0 | 0 | 0 | 0 | 0 | 0 | 0 | 0 | 0 | 0 | 1 | 1 | 1 | 1 | 1 | 0 |
| | Blue(63) | 0 | 0 | 0 | 0 | 0 | 0 | 0 | 0 | 0 | 0 | 0 | 0 | 1 | 1 | 1 | 1 | 1 | 1 |

6 Absolute Maximum Ratings

If the operating condition exceeds the following absolute maximum ratings, the TFT LCD module may be damaged permanently.

6.1 Environmental Absolute max. ratings

| Item | OPERATING | | STORAGE | | Remark |
|---------------|----------------|-----|----------------|-----|-------------------|
| | MIN | MAX | MIN | MAX | |
| Temperature | -20 | 70 | -30 | 80 | Note2,3,4,5,6,7,8 |
| Humidity | Note1 | | Note1 | | |
| Corrosive Gas | Not Acceptable | | Not Acceptable | | |

Note1 : $T_a \leq 40^\circ\text{C}$: 85% RH max

$T_a > 40^\circ\text{C}$: Absolute humidity must be lower than the humidity of 85%RH at 40°C

Note2 : For storage condition T_a at $-30^\circ\text{C} < 48\text{h}$, at $80^\circ\text{C} < 100\text{h}$

For operating condition T_a at $-20^\circ\text{C} < 100\text{h}$

Note3 : Background color changes slightly depending on ambient temperature. This phenomenon is reversible.

Note4 : The response time will be slower at low temperature.

Note5 : Only operation is guaranteed at operating temperature. Contrast , response time, another display quality are evaluated at $+25^\circ\text{C}$

Note6 : When LCM is operated over 40°C ambient temperature, the I_{LED} of the LED back-light should be follow :

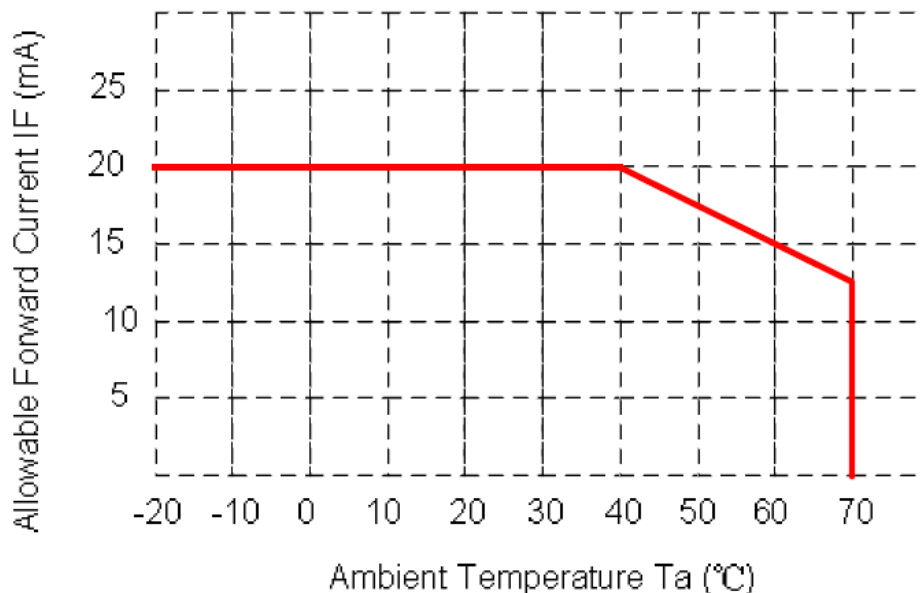

Note7 : This is panel surface temperature, not ambient temperature.

Note8 : When LCM be operated over than 40°C , the life time of the LED back-light will be reduced.

6.2 Electrical Absolute max. ratings

| Item | Symbol | Condition | Min. | Max. | Unit | Remark |
|---------------|-----------------|-----------|------|---------|------|--------|
| Power voltage | VDD | VSS=0 | -0.3 | 6.0 | V | |
| Input voltage | V _{in} | | -0.3 | VDD+0.3 | V | Note 1 |

Note1:Hsync, Vsync, DEN, DCLK, R0~R5, G0~G5, B0~B5

7 Electrical Characteristics

7.1 DC Electrical characteristic of the LCD

Typical operating conditions (VSS=0V)

| Item | Symbol | Min. | Typ. | Max. | Unit | Remark | |
|----------------------------|---------|-----------------|---------|------|---------|--------|--------|
| Power supply | VDD | 3.0 | 3.3 | 3.6 | V | | |
| Input Voltage for logic | H Level | V _{IH} | 0.7 VDD | - | VDD | V | Note 1 |
| | L Level | V _{IL} | 0 | - | 0.3 VDD | V | |
| Power Supply current | IDD | -- | 185 | -- | mA | Note 2 | |

Note1: Hsync, Vsync, DEN, DCLK, R0~R5, G0~G5, B0~B5

Note2: fv =60Hz , Ta=25°C , Display pattern : All Black

7.2 Electrical characteristic of LED Back-light

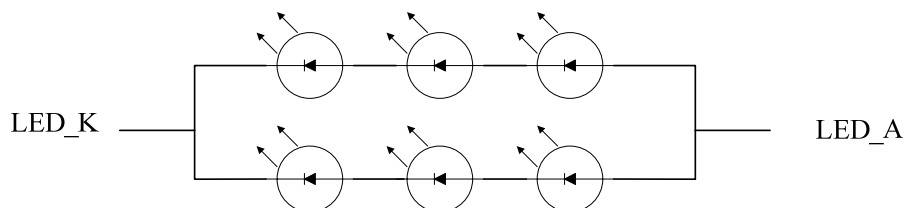
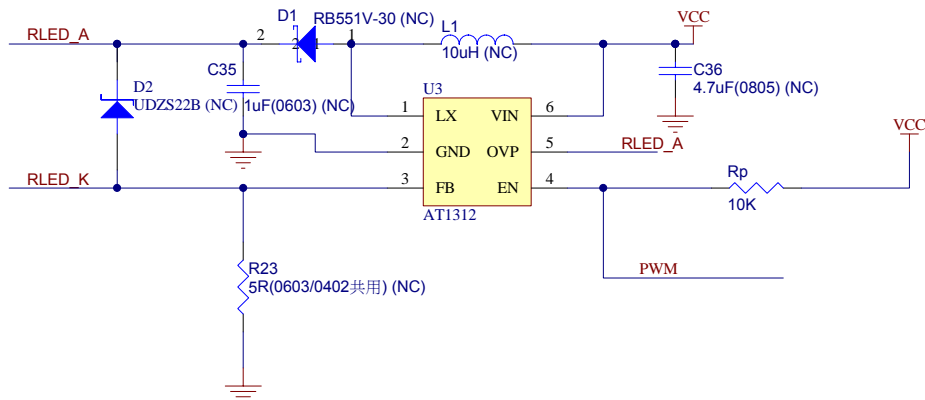

8 AC Timing characteristic of the LCD

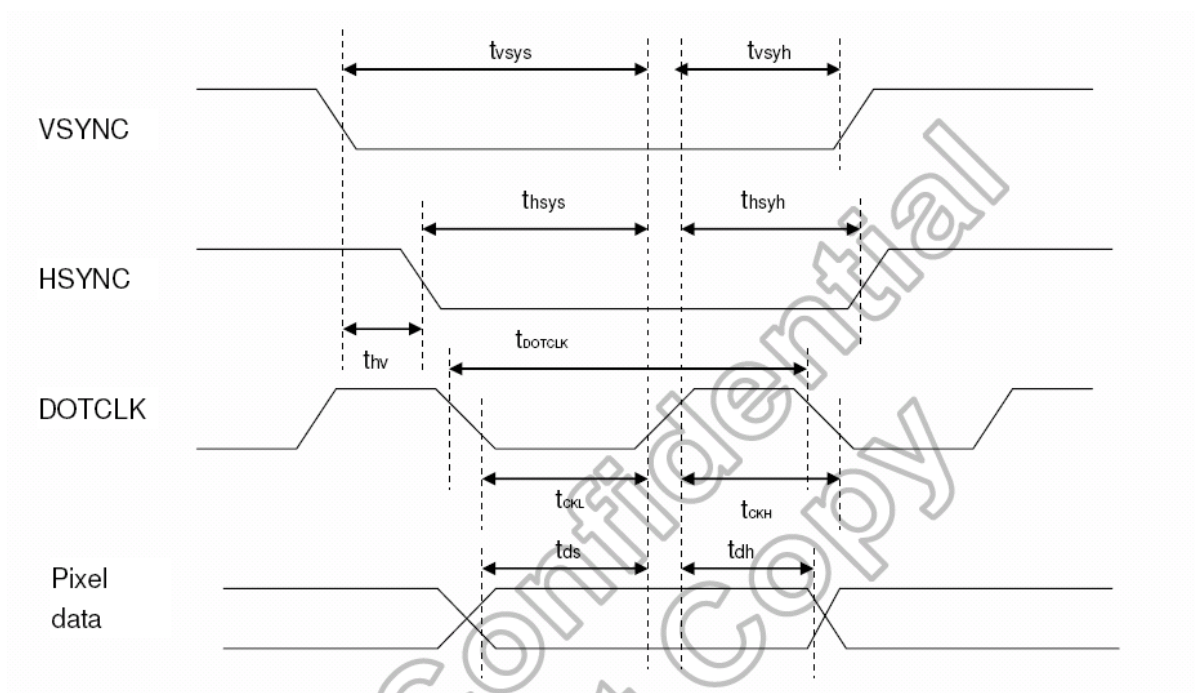

| Characteristics | Symbol | Min | | Typ | | Max | | Unit |
|----------------------------------------------|---------|--------|-------|--------|-------|--------|-------|---------|
| | | 24 bit | 8 bit | 24 bit | 8 bit | 24 bit | 8 bit | |
| DOTCLK Frequency | fDOTCLK | - | - | 6.5 | 19.5 | 10 | 30 | MHz |
| DOTCLK Period | tDOTCLK | 100 | 33.3 | 154 | 51.3 | - | - | ns |
| Vertical Sync Setup Time | tvsys | 20 | 10 | - | - | - | - | ns |
| Vertical Sync Hold Time | tvsyh | 20 | 10 | - | - | - | - | ns |
| Horizontal Sync Setup Time | thsys | 20 | 10 | - | - | - | - | ns |
| Horizontal Sync Hold Time | thsyh | 20 | 10 | - | - | - | - | ns |
| Phase difference of Sync Signal Falling Edge | thv | 1 | | - | | 240 | | tDOTCLK |
| DOTCLK Low Period | tCKL | 50 | 15 | - | - | - | - | ns |
| DOTCLK High Period | tCKH | 50 | 15 | - | - | - | - | ns |
| Data Setup Time | tds | 12 | 10 | - | - | - | - | ns |
| Data hold Time | tdh | 12 | 10 | - | - | - | - | ns |
| Reset pulse width | tRES | 10 | | - | | - | | us |

Note: External clock source must be provided to DOTCLK pin of HX8238-A. The driver will not operate if absent of the clocking signal.

Pixel Timing Table

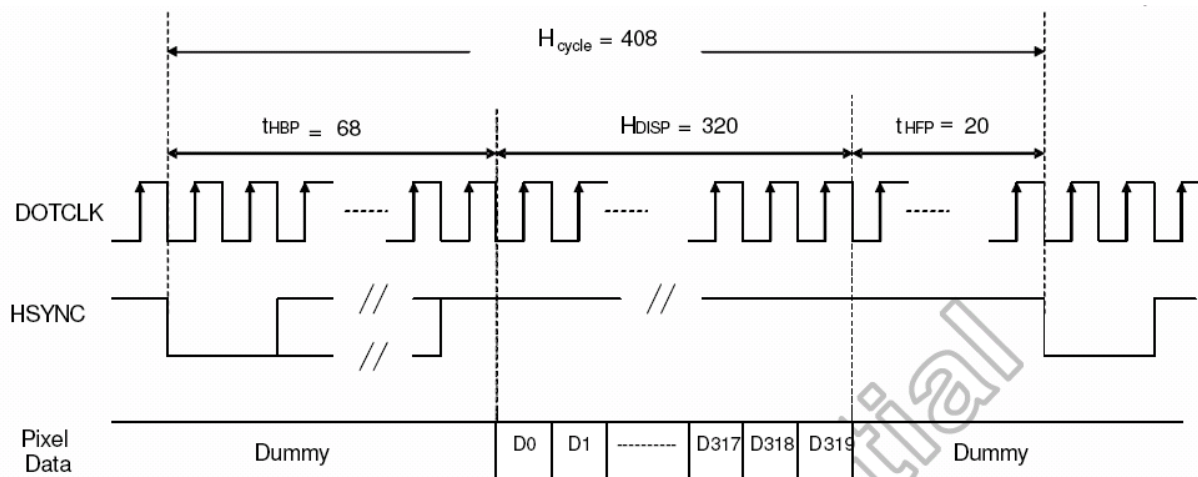

a) Horizontal Data Transaction Timing

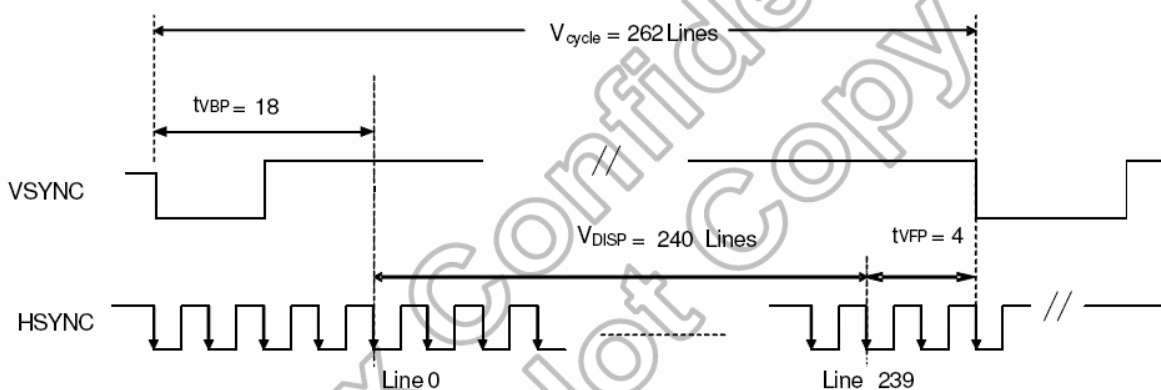

b) Vertical Data Transaction Timing

(a) Data Transaction Timing in Parallel RGB (24 bit) Interface (SYNC Mode)

| Characteristics | Symbol | Min | | Typ | | Max | | Unit |
|------------------------------|-------------|--------|-------|-------------|-------|--------|-------|---------|
| | | 24 bit | 8 bit | 24 bit | 8 bit | 24 bit | 8 bit | |
| DOTCLK Frequency | fDOTCLK | - | - | 6.5 | 19.5 | 10 | 30 | MHz |
| DOTCLK Period | tDOTCLK | 100 | 33.3 | 154 | 51.3 | - | - | ns |
| Horizontal Frequency (Line) | fH | - | - | 14.9 | | 22.35 | | KHz |
| Vertical Frequency (Refresh) | fV | - | - | 60 | | 90 | | Hz |
| Horizontal Back Porch | tHBP | - | - | 68 | 204 | - | - | tDOTCLK |
| Horizontal Front Porch | tHFP | - | - | 20 | 60 | - | - | tDOTCLK |
| Horizontal Data Start Point | tHBP | - | - | 68 | 204 | - | - | tDOTCLK |
| Horizontal Blanking Period | tHBP + tHFP | - | - | 88 | 264 | - | - | tDOTCLK |
| Horizontal Display Area | H_DISP | - | - | 320 | 960 | - | - | tDOTCLK |
| Horizontal Cycle | H_cycle | - | - | 408 | 1224 | 450 | 1350 | tDOTCLK |
| Vertical Back Porch | tVBP | - | - | 18 | | - | | Lines |
| Vertical Front Porch | tVFP | - | - | 4 | | - | | Lines |
| Vertical Data Start Point | tVBP | - | - | 18 | | - | | Lines |
| Vertical Blanking Period | tVBP + tVFP | - | - | 22 | | - | | Lines |
| Vertical Display Area | V_DISP | - | - | 240 | | - | | Lines |
| | | | | 280(PALM=0) | | | | |
| | | | | 288(PALM=1) | | | | |
| Vertical Cycle | V_cycle | - | - | 262 | | 350 | | Lines |
| | | | | 313 | | | | |

Data Transaction Timing in Normal Operating Mode

9 Optical specification

9.1 Optical characteristic of the LCD

| Item | Symbol | Condition | Min. | Typ. | Max. | Unit | Remark |
|--------------------|-----------|---------------------------------|------|------|------|----------|--------------|
| Response Time | T_r+T_f | $\Theta=0^\circ$ | | 50 | 80 | ms | Note 1,2,3,5 |
| Contrast ratio | CR | At optimized viewing angle | - | 300 | - | | Note 1,2,4,5 |
| Viewing Angle | Top | $CR \geq 10$ | - | 70 | - | deg. | Note1,2, 5,6 |
| | Bottom | | - | 70 | - | | |
| | Left | | - | 80 | - | | |
| | Right | | - | 80 | - | | |
| Brightness | Y_L | $I_{LED}=20mA$ $,25^\circ C$ | 250 | 280 | - | cd/m^2 | Note 7 |
| White chromaticity | XW | | 0.26 | - | 0.34 | | |
| | YW | | 0.27 | - | 0.35 | | |

() For reference only. These data should be update according the prototype.

Note 1: Note 1: Ambient temperature= $25^\circ C$, and lamp current $I_{LED}=20mA$. To be measured in the dark room.

Note 2: To be measured on the center area of panel with a viewing cone of 1° by Topcon luminance meter BM-7, after 10 minutes operation.

Note 3. Definition of response time:

The output signals of photo detector are measured when the input signals are changed from "black" to "white" (falling time) and from "white" to "black" (rising time), respectively. The response time is defined as the time interval between the 10% and 90% of amplitudes. Refer to figure as below.

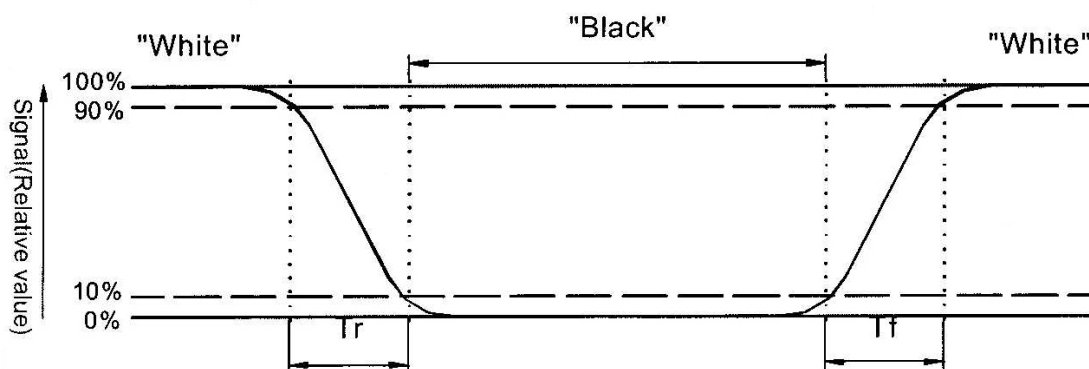

Note 4. Definition of contrast ratio:

Contrast ratio is calculated with the following formula.

$$\text{Contrast ratio (CR)} = \frac{\text{Photo detector output when LCD is at "White" state}}{\text{Photo detector Output when LCD is at "Black" state}}$$

Note 5: White $V_i = V_{i50} + 1.5V$

Black $V_i = V_{i50} + 2.0V$

“±” means that the analog input signal swings in phase with V_{COM} signal.

“-” means that the analog input signal swings out of phase with V_{COM} signal.

V_{i50} : The analog input voltage when transmission is 50%. The 100% Transmission is defined as the transmission of LCD panel when all the Input terminals of module are electrically opened.

Note 6. Definition of viewing angle, Refer to figure as below.

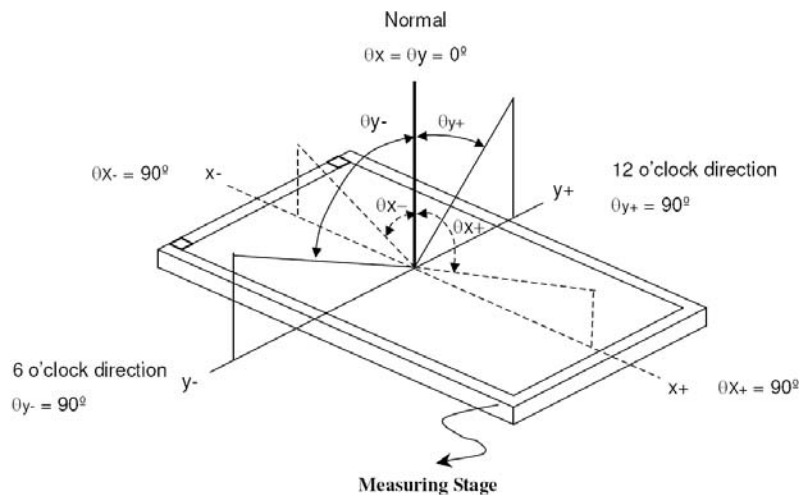

Note 7. Measured at the center area of the panel when all the input terminals of LCD panel are electrically opened.

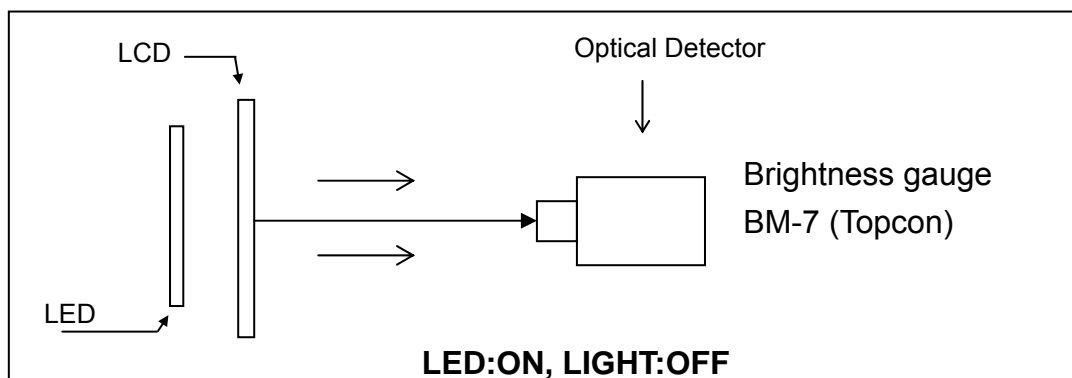
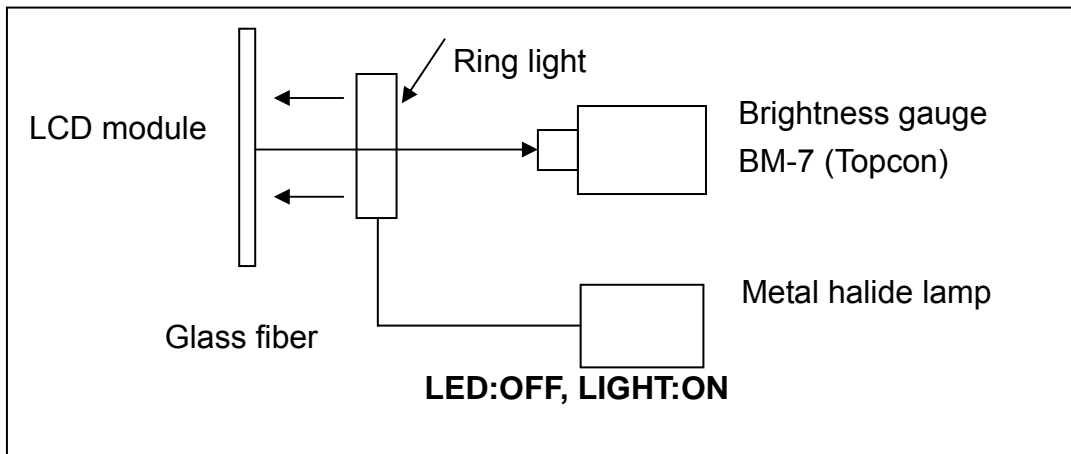

10 QUALITY AND RELIABILITY

10.1 TEST CONDITIONS

Tests should be conducted under the following conditions:

Ambient temperature: $25 \pm 5^{\circ}\text{C}$

Humidity : $60 \pm 25\% \text{ RH}$.

10.2 SAMPLING PLAN

Sampling method shall be in accordance with MIL-STD-105E, level II, normal single sampling plan .

10.3 ACCEPTABLE QUALITY LEVEL

A major defect is defined as one that could cause failure to or materially reduce the usability of the unit for its intended purpose. A minor defect is one that does not materially reduce the usability of the unit for its intended purpose or is an infringement from established standards and has no significant bearing on its effective use or operation.

10.4 APPEARANCE

An appearance test should be conducted by human sight at approximately 30 cm distance from the LCD module under fluorescent light. The inspection area of LCD panel shall be within the range of following limits.

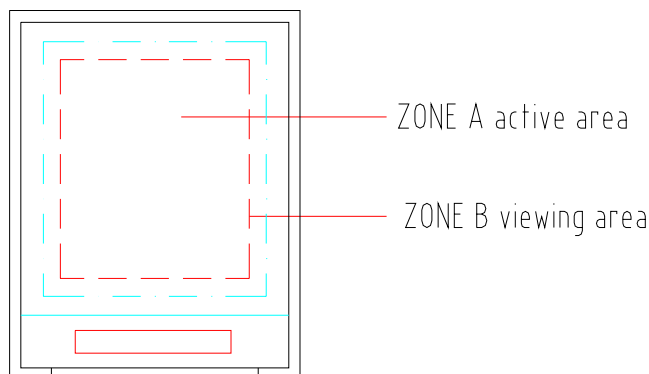

10.5 INSPECTION QUALITY CRITERIA

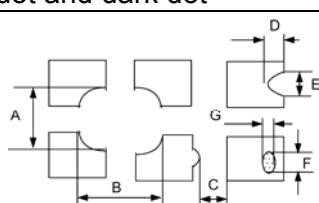
| No. | Item | Criterion for defects | Defect type | | | | | | | | | | | | | | | |
|------------------------------------------------|---------------------------------------------------------------|-------------------------------------------------------------------------------------------------------------------------------------------------------------------------------------------------------------------------------------------------------------------------------------------------------------------------------------------------------------------------------------------------------------------------------------------------------------------------------------------------------------------------------------------------------------------------------------------------------------------------------------------------------------------------------------------------------------------------------------------------------------------------------------------------------------------------------------------------------------------------------------------------------------------------------------------------------------------------------------------------------------------------------------------------------------|---------------------------|-------------------|---------------------------|---------------------------|---------------------------------------------|------------|------------------------------------------------|-----------------------|------------|--------------------|----------------------|---|--------------|----------------------|---|-------|
| 1 | Non display | No non display is allowed | Major | | | | | | | | | | | | | | | |
| 2 | Irregular operation | No irregular operation is allowed | Major | | | | | | | | | | | | | | | |
| 3 | Short | No short are allowed | Major | | | | | | | | | | | | | | | |
| 4 | Open | Any segments or common patterns that don't activate are rejectable. | Major | | | | | | | | | | | | | | | |
| 5 | Black/White spot | <table border="1" style="width: 100%; border-collapse: collapse;"> <thead> <tr> <th style="text-align: center;">Size D (mm)</th> <th style="text-align: center;">Acceptable number</th> </tr> </thead> <tbody> <tr> <td style="text-align: center;">$D \leq 0.15$</td> <td style="text-align: center;">Ignore</td> </tr> <tr> <td style="text-align: center;">$0.15 < D \leq 0.20$</td> <td style="text-align: center;">3</td> </tr> <tr> <td style="text-align: center;">$0.20 < D \leq 0.30$</td> <td style="text-align: center;">2</td> </tr> <tr> <td style="text-align: center;">$0.30 < D$</td> <td style="text-align: center;">0</td> </tr> </tbody> </table> | Size D (mm) | Acceptable number | $D \leq 0.15$ | Ignore | $0.15 < D \leq 0.20$ | 3 | $0.20 < D \leq 0.30$ | 2 | $0.30 < D$ | 0 | Minor | | | | | |
| Size D (mm) | Acceptable number | | | | | | | | | | | | | | | | | |
| $D \leq 0.15$ | Ignore | | | | | | | | | | | | | | | | | |
| $0.15 < D \leq 0.20$ | 3 | | | | | | | | | | | | | | | | | |
| $0.20 < D \leq 0.30$ | 2 | | | | | | | | | | | | | | | | | |
| $0.30 < D$ | 0 | | | | | | | | | | | | | | | | | |
| 6 | Black/White line | <table border="1" style="width: 100%; border-collapse: collapse;"> <thead> <tr> <th style="text-align: center;">Length(mm)</th> <th style="text-align: center;">Width (mm)</th> <th style="text-align: center;">Acceptable number</th> </tr> </thead> <tbody> <tr> <td style="text-align: center;">$10 < L$</td> <td style="text-align: center;">$0.03 < W \leq 0.04$</td> <td style="text-align: center;">5</td> </tr> <tr> <td style="text-align: center;">$5.0 < L \leq 10$</td> <td style="text-align: center;">$0.04 < W \leq 0.06$</td> <td style="text-align: center;">3</td> </tr> <tr> <td style="text-align: center;">$1.0 < L \leq 5.0$</td> <td style="text-align: center;">$0.06 < W \leq 0.07$</td> <td style="text-align: center;">2</td> </tr> <tr> <td style="text-align: center;">$L \leq 1.0$</td> <td style="text-align: center;">$0.07 < W \leq 0.09$</td> <td style="text-align: center;">1</td> </tr> </tbody> </table> | Length(mm) | Width (mm) | Acceptable number | $10 < L$ | $0.03 < W \leq 0.04$ | 5 | $5.0 < L \leq 10$ | $0.04 < W \leq 0.06$ | 3 | $1.0 < L \leq 5.0$ | $0.06 < W \leq 0.07$ | 2 | $L \leq 1.0$ | $0.07 < W \leq 0.09$ | 1 | Minor |
| Length(mm) | Width (mm) | Acceptable number | | | | | | | | | | | | | | | | |
| $10 < L$ | $0.03 < W \leq 0.04$ | 5 | | | | | | | | | | | | | | | | |
| $5.0 < L \leq 10$ | $0.04 < W \leq 0.06$ | 3 | | | | | | | | | | | | | | | | |
| $1.0 < L \leq 5.0$ | $0.06 < W \leq 0.07$ | 2 | | | | | | | | | | | | | | | | |
| $L \leq 1.0$ | $0.07 < W \leq 0.09$ | 1 | | | | | | | | | | | | | | | | |
| 7 | Back Light | 1. No Lighting is rejectable 2. Flickering and abnormal lighting are rejectable | Major | | | | | | | | | | | | | | | |
| 8 | dot defect | <table border="1" style="width: 100%; border-collapse: collapse;"> <tbody> <tr> <td style="text-align: center;">Bright dot</td> <td style="text-align: center;">$N \leq 1$</td> </tr> <tr> <td style="text-align: center;">Dark dot</td> <td style="text-align: center;">$N \leq 3$</td> </tr> <tr> <td style="text-align: center;">Total dot defect (Bright dot + Dark dot)</td> <td style="text-align: center;">$N \leq 3$</td> </tr> <tr> <td style="text-align: center;">Minimum distance between dark dot and dark dot</td> <td style="text-align: center;">$L \geq 5 \text{ mm}$</td> </tr> </tbody> </table> | Bright dot | $N \leq 1$ | Dark dot | $N \leq 3$ | Total dot defect (Bright dot + Dark dot) | $N \leq 3$ | Minimum distance between dark dot and dark dot | $L \geq 5 \text{ mm}$ | Minor | | | | | | | |
| Bright dot | $N \leq 1$ | | | | | | | | | | | | | | | | | |
| Dark dot | $N \leq 3$ | | | | | | | | | | | | | | | | | |
| Total dot defect (Bright dot + Dark dot) | $N \leq 3$ | | | | | | | | | | | | | | | | | |
| Minimum distance between dark dot and dark dot | $L \geq 5 \text{ mm}$ | | | | | | | | | | | | | | | | | |
| 9 | Display pattern | <div style="text-align: center;">  <p style="text-align: center;">Unit:mm</p> <table border="1" style="width: 100%; border-collapse: collapse;"> <tbody> <tr> <td style="text-align: center;">$\frac{A+B}{2} \leq 0.30$</td> <td style="text-align: center;">$0 < C$</td> <td style="text-align: center;">$\frac{D+E}{2} \leq 0.25$</td> <td style="text-align: center;">$\frac{F+G}{2} \leq 0.25$</td> </tr> </tbody> </table> <p style="text-align: center;">Note: 1. Acceptable up to 3 damages 2. NG if there're to two or more pinholes per dot</p> </div> | $\frac{A+B}{2} \leq 0.30$ | $0 < C$ | $\frac{D+E}{2} \leq 0.25$ | $\frac{F+G}{2} \leq 0.25$ | Minor | | | | | | | | | | | |
| $\frac{A+B}{2} \leq 0.30$ | $0 < C$ | $\frac{D+E}{2} \leq 0.25$ | $\frac{F+G}{2} \leq 0.25$ | | | | | | | | | | | | | | | |
| 10 | Blemish & Foreign matters Size: $D = \frac{A+B}{2}$ | <table border="1" style="width: 100%; border-collapse: collapse;"> <thead> <tr> <th style="text-align: center;">Size D (mm)</th> <th style="text-align: center;">Acceptable number</th> </tr> </thead> <tbody> <tr> <td style="text-align: center;">$D \leq 0.15$</td> <td style="text-align: center;">Ignore</td> </tr> <tr> <td style="text-align: center;">$0.15 < D \leq 0.20$</td> <td style="text-align: center;">3</td> </tr> <tr> <td style="text-align: center;">$0.20 < D \leq 0.30$</td> <td style="text-align: center;">2</td> </tr> <tr> <td style="text-align: center;">$0.30 < D$</td> <td style="text-align: center;">0</td> </tr> </tbody> </table> | Size D (mm) | Acceptable number | $D \leq 0.15$ | Ignore | $0.15 < D \leq 0.20$ | 3 | $0.20 < D \leq 0.30$ | 2 | $0.30 < D$ | 0 | Minor | | | | | |
| Size D (mm) | Acceptable number | | | | | | | | | | | | | | | | | |
| $D \leq 0.15$ | Ignore | | | | | | | | | | | | | | | | | |
| $0.15 < D \leq 0.20$ | 3 | | | | | | | | | | | | | | | | | |
| $0.20 < D \leq 0.30$ | 2 | | | | | | | | | | | | | | | | | |
| $0.30 < D$ | 0 | | | | | | | | | | | | | | | | | |

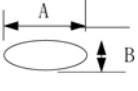
| 11 | Scratch on Polarizer  | <table border="1"> <thead> <tr> <th>Width (mm)</th> <th>Length (mm)</th> <th>Acceptable number</th> </tr> </thead> <tbody> <tr> <td>$W \leq 0.03$</td> <td>Ignore</td> <td>Ignore</td> </tr> <tr> <td>$0.03 < W \leq 0.05$</td> <td>$L \leq 2.0$</td> <td>Ignore</td> </tr> <tr> <td></td> <td>$L > 2.0$</td> <td>1</td> </tr> <tr> <td>$0.05 < W \leq 0.08$</td> <td>$L > 1.0$</td> <td>1</td> </tr> <tr> <td></td> <td>$L \leq 1.0$</td> <td>Ignore</td> </tr> <tr> <td>$0.08 < W$</td> <td>Note (1)</td> <td>Note(1)</td> </tr> </tbody> </table> | Width (mm) | Length (mm) | Acceptable number | $W \leq 0.03$ | Ignore | Ignore | $0.03 < W \leq 0.05$ | $L \leq 2.0$ | Ignore | | $L > 2.0$ | 1 | $0.05 < W \leq 0.08$ | $L > 1.0$ | 1 | | $L \leq 1.0$ | Ignore | $0.08 < W$ | Note (1) | Note(1) | Minor |
|-----------------------------|-----------------------------------------------------------------------------------------------------------|-------------------------------------------------------------------------------------------------------------------------------------------------------------------------------------------------------------------------------------------------------------------------------------------------------------------------------------------------------------------------------------------------------------------------------------------------------------------------------------------------------------------------------------------------------------------------------------------------------------------------------------------------------------|-------------------------|-------------------|-------------------|---------------|----------------------|--------|----------------------|--------------|------------|---|-----------|---|----------------------|-----------|---|--|--------------|--------|------------|----------|---------|-------|
| | | Width (mm) | Length (mm) | Acceptable number | | | | | | | | | | | | | | | | | | | | |
| $W \leq 0.03$ | Ignore | Ignore | | | | | | | | | | | | | | | | | | | | | | |
| $0.03 < W \leq 0.05$ | $L \leq 2.0$ | Ignore | | | | | | | | | | | | | | | | | | | | | | |
| | $L > 2.0$ | 1 | | | | | | | | | | | | | | | | | | | | | | |
| $0.05 < W \leq 0.08$ | $L > 1.0$ | 1 | | | | | | | | | | | | | | | | | | | | | | |
| | $L \leq 1.0$ | Ignore | | | | | | | | | | | | | | | | | | | | | | |
| $0.08 < W$ | Note (1) | Note(1) | | | | | | | | | | | | | | | | | | | | | | |
| Note(1) Regard as a blemish | | | | | | | | | | | | | | | | | | | | | | | | |
| 12 | Bubble in polarizer | <table border="1"> <thead> <tr> <th>Size D (mm)</th> <th>Acceptable number</th> </tr> </thead> <tbody> <tr> <td>$D \leq 0.20$</td> <td>Ignore</td> </tr> <tr> <td>$0.20 < D \leq 0.50$</td> <td>3</td> </tr> <tr> <td>$0.50 < D \leq 0.80$</td> <td>2</td> </tr> <tr> <td>$0.80 < D$</td> <td>0</td> </tr> </tbody> </table> | Size D (mm) | Acceptable number | $D \leq 0.20$ | Ignore | $0.20 < D \leq 0.50$ | 3 | $0.50 < D \leq 0.80$ | 2 | $0.80 < D$ | 0 | Minor | | | | | | | | | | | |
| | | Size D (mm) | Acceptable number | | | | | | | | | | | | | | | | | | | | | |
| $D \leq 0.20$ | Ignore | | | | | | | | | | | | | | | | | | | | | | | |
| $0.20 < D \leq 0.50$ | 3 | | | | | | | | | | | | | | | | | | | | | | | |
| $0.50 < D \leq 0.80$ | 2 | | | | | | | | | | | | | | | | | | | | | | | |
| $0.80 < D$ | 0 | | | | | | | | | | | | | | | | | | | | | | | |
| | | | | | | | | | | | | | | | | | | | | | | | | |
| 13 | Stains on LCD panel surface | Stains that cannot be removed even when wiped lightly with a soft cloth or similar cleaning tool are rejectable. | Minor | | | | | | | | | | | | | | | | | | | | | |
| 14 | Rust in Bezel | Rust which is visible in the bezel is rejectable. | Minor | | | | | | | | | | | | | | | | | | | | | |
| 15 | Defect of land surface contact (poor soldering) | Evident crevices which is visible are rejectable. | Minor | | | | | | | | | | | | | | | | | | | | | |
| 16 | Parts mounting | <ol style="list-style-type: none"> 1. Failure to mount parts 2. Parts not in the specifications are mounted 3. Polarity, for example, is reversed | Major Major Major | | | | | | | | | | | | | | | | | | | | | |
| 17 | Parts alignment | 1. LSI, IC lead width is more than 50% beyond pad outline. | Minor | | | | | | | | | | | | | | | | | | | | | |
| | | 2. Chip component is off center and more than 50% of the leads is off the pad outline. | Minor | | | | | | | | | | | | | | | | | | | | | |
| 18 | Conductive foreign matter (Solder ball, Solder chips) | 1. $0.45 < \phi$, $N \geq 1$ | Major | | | | | | | | | | | | | | | | | | | | | |
| | | 2. $0.30 < \phi \leq 0.45$, $N \geq 1$ ϕ : Average diameter of solder ball (unit: mm) | Minor | | | | | | | | | | | | | | | | | | | | | |
| 19 | Faulty PCB correction | 3. $0.50 < L$, $N \geq 1$ L: Average length of solder chip (unit: mm) | Minor | | | | | | | | | | | | | | | | | | | | | |
| | | <ol style="list-style-type: none"> 1. Due to PCB copper foil pattern burnout, the pattern is connected, using a jumper wire for repair; 2 or more places are corrected per PCB. 2. Short circuited part is cut, and no resist coating has been performed. | Minor Minor | | | | | | | | | | | | | | | | | | | | | |

10.6 RELIABILITY

| Test Item | Test Conditions | Note |
|----------------------------|-------------------------------------------------------------------------------------------------------------------------|------|
| High Temperature Operation | 70±3°C , t=96 hrs | |
| Low Temperature Operation | -20±3°C , t=96 hrs | |
| High Temperature Storage | 80±3°C , t=96 hrs | 1,2 |
| Low Temperature Storage | -30±3°C , t=96 hrs | 1,2 |
| Humidity Test | 40°C , Humidity 90%, 96 hrs | 1,2 |
| Thermal Shock Test | -30°C ~ 25°C ~ 80°C 30 min. 5 min. 30 min. (1 cycle) Total 5 cycle | 1,2 |
| Vibration Test (Packing) | Sweep frequency : 10~55~10 Hz/1min Amplitude : 0.75mm Test direction : X.Y.Z/3 axis Duration : 30min/each axis | 2 |
| Static Electricity | 150pF 330 ohm ±8kV, 10times air discharge | |

Note 1 : Condensation of water is not permitted on the module.

Note 2 : The module should be inspected after 1 hour storage in normal conditions

(15-35°C , 45-65%RH).

Definitions of life end point :

- Current drain should be smaller than the specific value.
- Function of the module should be maintained.
- Appearance and display quality should not have degraded noticeably.
- Contrast ratio should be greater than 50% of the initial value.

11 USE PRECAUTIONS

11.1 Handling precautions

- 1) The polarizing plate may break easily so be careful when handling it. Do not touch, press or rub it with a hard-material tool like tweezers.
- 2) Do not touch the polarizing plate surface with bare hands so as not to make it dirty. If the surface or other related part of the polarizing plate is dirty, soak a soft cotton cloth or chamois leather in benzine and wipe off with it. Do not use chemical liquids such as acetone, toluene and isopropyl alcohol. Failure to do so may bring chemical reaction phenomena and deteriorations.
- 3) Remove any spit or water immediately. If it is left for hours, the suffered part may deform or decolorize.

- 4) If the LCD element breaks and any LC stuff leaks, do not suck or lick it. Also if LC stuff is stuck on your skin or clothing, wash thoroughly with soap and water immediately.

11.2 Installing precautions

- 1) To prevent breaking by static electricity from the human body and clothing, earth the human body properly using the high resistance and discharge static electricity during the operation. In this case, however, the resistance value should be approx. $1M\Omega$ and the resistance should be placed near the human body rather than the ground surface. When the indoor space is dry, static electricity may occur easily so be careful. We recommend the indoor space should be kept with humidity of 60% or more. When a soldering iron or other similar tool is used for assembly, be sure to earth it.
- 2) When installing the module and ICs, do not bend or twist them. Failure to do so may crack LC element and cause circuit failure.
- 3) To protect LC element, especially polarizing plate, use a transparent protective plate (e.g., acrylic plate, glass etc) for the product case.
- 4) Do not use an adhesive like a both-side adhesive tape to make LCD surface (polarizing plate) and product case stick together. Failure to do so may cause the polarizing plate to peel off.

11.3 Storage precautions

- 1) Avoid a high temperature and humidity area. Keep the temperature between 0°C and 35°C and also the humidity under 60%.
- 2) Choose the dark spaces where the product is not exposed to direct sunlight or fluorescent light.
- 3) Store the products as they are put in the boxes provided from us or in the same conditions as we recommend.

11.4 Operating precautions

- 1) Do not boost the applied drive voltage abnormally. Failure to do so may break ICs. When applying power voltage, check the electrical features beforehand and be careful. Always turn off the power to the LC module controller before removing or inserting the LC module input connector. If the input connector is removed or inserted while the power is turned on, the LC module internal circuit may break.

- 2) The display response may be late if the operating temperature is under the normal standard, and the display may be out of order if it is above the normal standard. But this is not a failure; this will be restored if it is within the normal standard.
- 3) The LCD contrast varies depending on the visual angle, ambient temperature, power voltage etc. Obtain the optimum contrast by adjusting the LC drive voltage.
- 4) When carrying out the test, do not take the module out of the low-temperature space suddenly. Failure to do so will cause the module condensing, leading to malfunctions.
- 5) Make certain that each signal noise level is within the standard (L level: 0.2V_{dd} or less and H level: 0.8V_{dd} or more) even if the module has functioned properly. If it is beyond the standard, the module may often malfunction. In addition, always connect the module when making noise level measurements.
- 6) The CMOS ICs are incorporated in the module and the pull-up and pull-down function is not adopted for the input so avoid putting the input signal open while the power is ON.
- 7) The characteristic of the semiconductor element changes when it is exposed to light emissions, therefore ICs on the LCD may malfunction if they receive light emissions. To prevent these malfunctions, design and assemble ICs so that they are shielded from light emissions.
- 8) Crosstalk occurs because of characteristics of the LCD. In general, crosstalk occurs when the regularized display is maintained. Also, crosstalk is affected by the LC drive voltage. Design the contents of the display, considering crosstalk.

11.5 Other

- 1) Do not disassemble or take the LC module into pieces. The LC modules once disassembled or taken into pieces are not the guarantee articles.
- 2) The residual image may exist if the same display pattern is shown for hours. This residual image, however, disappears when another display pattern is shown or the drive is interrupted and left for a while. But this is not a problem on reliability.
- 3) AMIPRE will provide one year warranty for all products and three months warranty for all repairing products.

12 Mechanical Dimensions

