



晶采光電科技股份有限公司
AMPIRE CO., LTD.

SPECIFICATIONS FOR LCD MODULE

CUSTOMER	
CUSTOMER PART NO.	
AMPIRE PART NO.	AM480272H3TMQW-TW1H
APPROVED BY	
DATE	

- Approved For Specifications
 Approved For Specifications & Sample

AMPIRE CO., LTD.

**2F., No.88, Sec. 1, Sintai 5th Rd., Sijhih City, Taipei County 221,
Taiwan (R.O.C.)台北縣汐止市新台五路一段 88 號 2 樓(東方科學園區 D 棟)
TEL:886-2-26967269 , FAX:886-2-26967196 or 26967270**

APPROVED BY	CHECKED BY	ORGANIZED BY

RECORD OF REVISION

Revision Date	Page	Contents	Editor
2009/4/17	--	New Release 80/8Bit MCU interface+Touch Panel+Touch Panel controller TSC2046	Kokai
2009/12/7		Change the LED back-light Brightness	Kokai

1 Features

4.3 inch Amorphous-TFT-LCD (Thin Film Transistor Liquid Crystal Display) module. This module is composed of a 4.3" TFT-LCD panel, LCD controller, power driver circuit, touch panel and backlight unit.

1.1 TFT Panel Feature :

- (1) Construction: 4.3" a-Si color TFT-LCD, White LED Backlight and PCB.
- (2) Resolution (pixel): 480(R.G.B) X 272
- (3) Number of the Colors : 262K colors (R , G , B 6 bit digital each)
- (4) LCD type : Transmissive Color TFT LCD (normally White)
- (5) Interface: 40 pin pitch 0.5
- (6) Power Supply Voltage: 3.3V single power input. Built-in power supply circuit.
- (7) Viewing Direction: 6 O'clock (The direction it's hard to be discolored):

1.2 LCD Controller Feature:

- (1) MCU interface 8/9/16/18 bit 80&68 series MCU interface.
- (2) Display RAM size : 640x320x3x6 bits. Ex : 320x240 two frame buffer with 262K colors.
- (3) Arbitrary display memory start position selection.
- (4) MCU interface : 8 bit / 9 bit / 16bit / 18 bits 80/68 MPU interface.
- (5) 8 bit / 16 bit interface support 65K (R5G6B5) /262K(R6G6B6) colors data format.
- (6) 9 bit / 18 bit interface support 262K(R6G6B6) colors data format only.

2 Physical specifications

Item	Specifications	Unit
Display resolution(dot)	480(R.G.B.) (W) x 272(H)	mm
Active area	95.04 (W) x 53.856 (H)	mm
Screen size	4.3 (Diagonal)	mm
Pixel size	0.198 (W) x 0.198 (H)	um
Color configuration	R.G.B stripe	
Overall dimension	105.5(W) x 67.2(H) x 7.61(D)	mm
Weight	T.B.D	mg
Backlight unit	LED	

3 Default Setting & Option

- Interface :

The user can select the MCU interface by change the Jumper & Resister Array.

Setting / Interface Type	JP1	RA1	RA2	RA3	RA4	Remark
80-18Bit interface	1,2 short 2,3 open	2K ohm	OPEN	OPEN	OPEN	
80-16Bit interface	1,2 short 2,3 open	OPEN	2K ohm	OPEN	OPEN	
80-9Bit interface	1,2 short 2,3 open	OPEN	OPEN	2K ohm	OPEN	
80-8Bit interface	1,2 short 2,3 open	OPEN	OPEN	OPEN	2K ohm	Default
68-18Bit interface	1,2 open 2,3 short	2K ohm	OPEN	OPEN	OPEN	
68-16Bit interface	1,2 open 2,3 short	OPEN	2K ohm	OPEN	OPEN	
68-9Bit interface	1,2 open 2,3 short	OPEN	OPEN	2K ohm	OPEN	
68-8Bit interface	1,2 open 2,3 short	OPEN	OPEN	OPEN	2K ohm	

- LED Driver:

The user can select the LED driver built-in or not.

Pin Define / Interface Type	PIN3 LEDA/PWM	PIN4 LEDK	Remark
Without LED Driver	LED Anode	LED Cathode	
With LED Driver	<p align="center">PWM</p> <p>The PWM pin combined enable and brightness adjust function. When PWM=High constantly, the LED back-light is turn on. When PWM=GND constantly, the LED back-light is turn off. When PWM signal (100Hz to 1KHz) input, the LED Back-light brightness is relative to duty cycle of the PWM signal.</p>	<p align="center">NC</p> <p>This pin must be open</p>	Default

- Touch panel and Touch panel controller:

The user can select the with TP controller or without TP controller.

Pin Define Option	SK/X1	DO/X2	DI/Y1	TPCS/Y2	IRQ	Remark
Without TP	NC	NC	NC	NC	NC	
With TP / Without TP controller	X1	X2	Y1	Y2	NC	
With TP / With TP controller	SK	DO	DI	TPCS	IRQ	Default

If user want to change the default setting for mass production, please contact with Ampire. We'll apply a new P/N for you.

4 Electrical specification

4.1 Absolute max. ratings

4.1.1 Electrical Absolute max. ratings

Item	Symbol	Condition	Min.	Max.	Unit	Remark
Power voltage	VDD	VSS=0	-0.3	T.B.D	V	
Input voltege	V _{in}		-0.3	VDD+0.3	V	Note 1

Note1: /CS,/WR,/RD,RS,DB0~DN17

4.1.2 Environmental Absolute max. ratings

Item	OPERATING		STORAGE		Remark
	MIN	MAX	MIN	MAX	
Temperature	-20	70	-30	80	Note2,3,4,5,6,7
Humidity	Note1		Note1		
Corrosive Gas	Not Acceptable		Not Acceptable		

Note1 : Ta ≤ 40°C : 85% RH max

Ta > 40°C : Absolute humidity must be lower than the humidity of 85%RH at 40°C

Note2 : For storage condition Ta at -30°C < 48h , at 80°C < 100h

For operating condition Ta at -20°C < 100h

Note3 : Background color changes slightly depending on ambient temperature. This phenomenon is reversible.

Note4 : The response time will be slower at low temperature.

Note5 : Only operation is guarantied at operating temperature. Contrast , response time, another display quality are evaluated at +25°C

Note6 :

- LED BL : When LCM is operated over 40°C ambient temperature, the I_{LED} of the LED back-light should be follow :

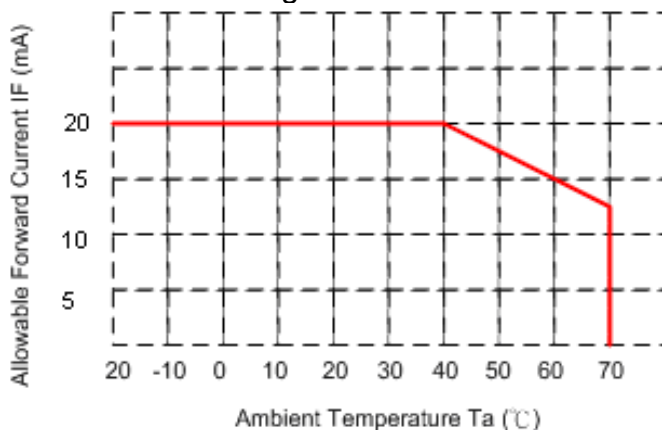

Note7 : This is panel surface temperature, not ambient temperature.

Note8 :

- LED BL:When LCM be operated over than 40°C , the life time of the LED back-light will be reduced.

4.1.3 LED back-light Unit Absolute max. ratings

Item	Symbol	Ratings	Unit	Remark
Pulse Forward Current	IF	100	mA	
Forward Current	IF	30	mA	
Reverse Voltage	VR	35	V	
Power Dissipation	Po	0.84	W	

4.2 Electrical characteristics

4.2.1 DC Electrical characteristic of the LCD

Typical operating conditions (VSS=0V)

Item	Symbol	Min.	Typ.	Max.	Unit	Remark	
Power supply	VDD	3.0	3.3	5.0	V		
Input Voltage for logic	H Level	V_{IH}	2.0	-	5.5	V	Note 1
	L Level	V_{IL}	VSS	-	0.8	V	
Output Voltage for Logic	H Level	V_{OH}	2.4	-	VDD	V	Note 2
	L Level	V_{OL}	VSS	-	0.4	V	
Power Supply current	IDD	-	450	-	mA	Note 3	

Note1: With 5V Tolerance Input , /CS, /WR,/RD,RS,DB0~DB17,TPCS, SK ,DI,DO,IRQ

Note2: DB0~DB17

Note3: $f_v = 60\text{Hz}$, $T_a = 25^\circ\text{C}$, Display pattern : All Black

4.2.2 Electrical characteristic of LED Back-light

Parameter	Symbol	Min.	Typ.	Max.	Unit	Condition
LED voltage	V_{AK}	--	23.1	--	V	$I_{LED} = 20\text{mA}$, $T_a = 25^\circ\text{C}$
LED forward current	I_{LED}	--	20	--	mA	$T_a = 25^\circ\text{C}$
	I_{LED}	--	15	--	mA	$T_a = 60^\circ\text{C}$

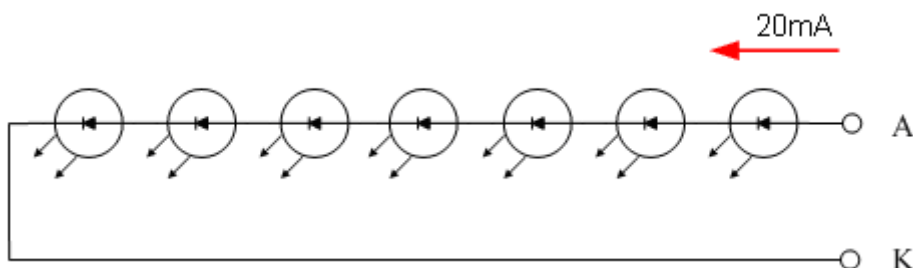

- The constant current source is needed for white LED back-light driving.

When LCM is operated over 60°C ambient temperature, the I_{LED} of the LED back-light should be adjusted to 15 mA.

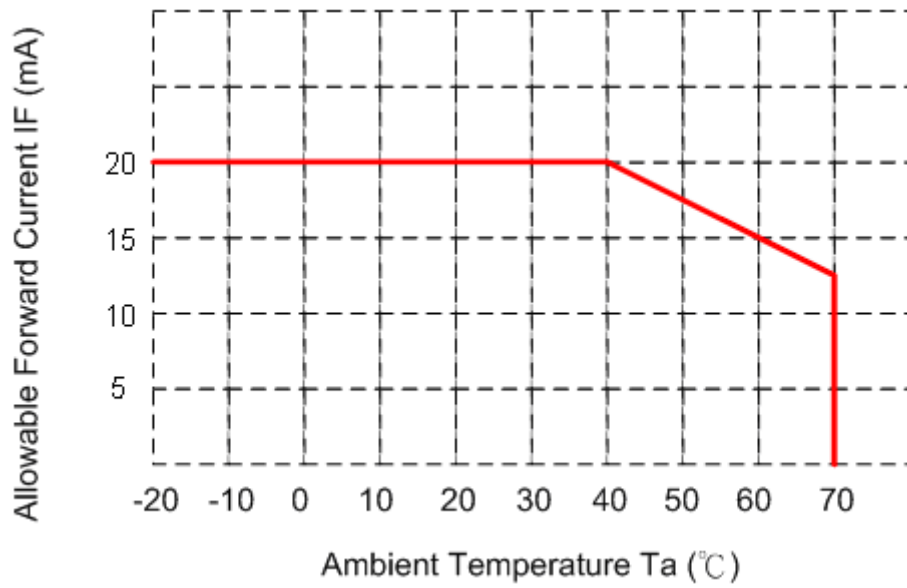

4.3 AC Timing characteristic of the Graphic TFT LCD controller

4.3.1 80 series Timing

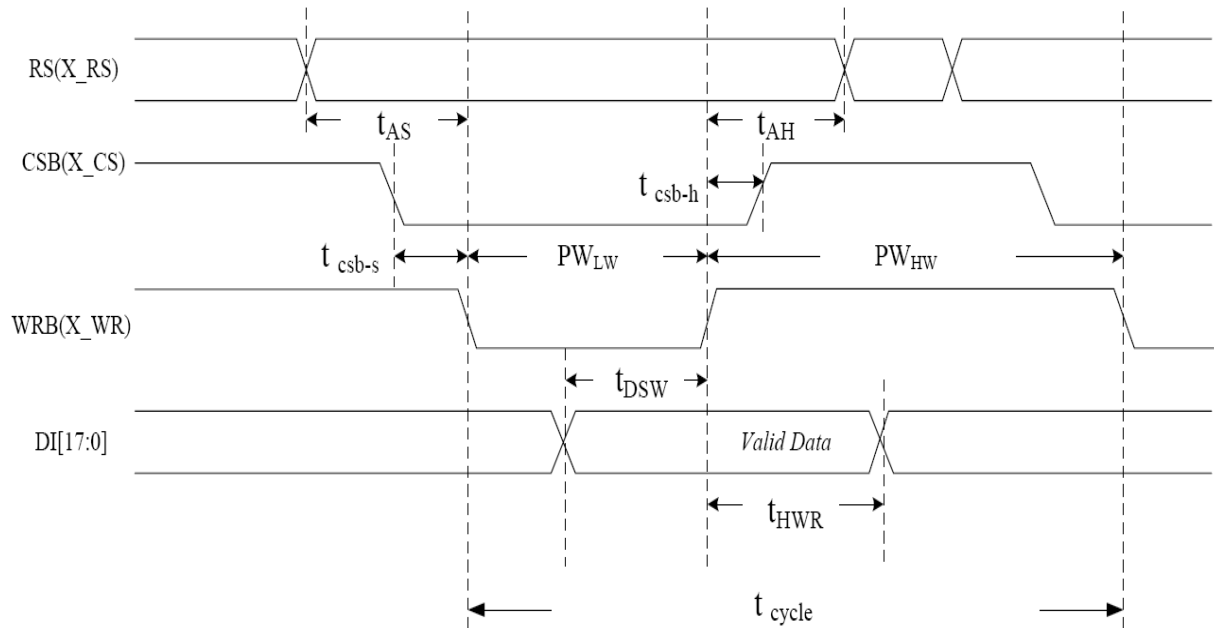

Symbol	Parameter	Min	Typ	Max	Unit	Remark
t_{cycle}	Enable cycle time	100	200		ns	
PW_{HW}	Enable high-level pulse width	66	70		ns	
PW_{LW}	Enable low-level pulse width	33	130		ns	
t_{AS}	RS setup time	16	25		ns	
t_{AH}	RS hold time	16	45		ns	
t_{DSW}	Write data setup time	50	50		ns	
t_{HWR}	Write data hold time	40	50		ns	
t_{csb-s}	CSB setup time	16	20		ns	
t_{csb-h}	CSB hold time	16	30		ns	

5 Optical specification

5.1 Optical characteristic :

Item		Symbol	Conditon	Min.	Typ.	Max.	Unit	Remark
Response Time	Rise	T_r	$\Theta=0^\circ$	--	15	20	ms	Note 1,2,3,5
	Fall	T_f		--	35	50		
Contrast ratio		CR	At optimized viewing angle	150	250	--		Note 1,2,4,5
Viewing Angle	Top		$CR \geq 10$	--	55	--	deg.	Note1,2, 5,6
	Bottom			--	35	--		
	Left			--	70	--		
	Right			--	70	--		
Brightness LED BL Without TP		Y_L	$I_{LED}=20mA, 25^\circ C$		500	--	cd/m ²	Note 7
Brightness LED BL With TP		Y_L	$I_{LED}=20mA, 25^\circ C$		400	--	cd/m ²	Note 7
Red chromaticity	X_R	$\Theta=0^\circ$		(0.585)	(0.615)	(0.645)		Note 7 For reference only. These data should be update according the prototype.
	Y_R			(0.314)	(0.344)	(0.374)		
Green chromaticity	X_G			(0.277)	(0.307)	(0.337)		
	Y_G			(0.532)	(0.562)	(0.592)		
Blue chromaticity	X_B			(0.103)	(0.133)	(0.163)		
	Y_B			(0.120)	(0.150)	(0.180)		
White chromaticity	X_W			(0.279)	(0.309)	(0.339)		
	Y_W			(0.320)	(0.350)	(0.380)		

() For reference only. These data should be update according the prototype.

Note 1:

- LED BL : Ambient temperature=25°C, and lamp current $I_{LED}=20mA$. To be measured in the dark room.

Note 2: To be measured on the center area of panel with a viewing cone of 1° by Topcon luminance meter BM-7, after 10 minutes operation.

Note 3. Definition of response time:

The output signals of photo detector are measured when the input signals are changed from "black" to "white" (falling time) and from "white" to "black" (rising time), respectively. The response time is defined as the time interval between the 10% and 90% of amplitudes. Refer to figure as below.

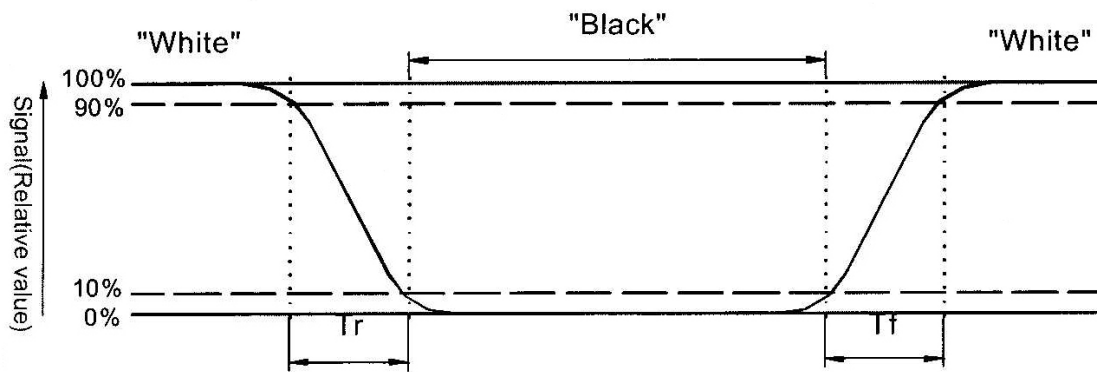

Note 4. Definition of contrast ratio:

Contrast ratio is calculated with the following formula.

$$\text{Contrast ratio(CR)} = \frac{\text{Photo detector output when LCD is at "White" state}}{\text{Photo detector Output when LCD is at "Black" state}}$$

Note 5: White $V_i = V_{i50} + 1.5V$

Black $V_i = V_{i50} + 2.0V$

“±” means that the analog input signal swings in phase with V_{COM} signal.

“ $\frac{-}{+}$ ” means that the analog input signal swings out of phase with V_{COM} signal.

V_{i50} : The analog input voltage when transmission is 50%. The 100% Transmission is defined as the transmission of LCD panel when all the Input terminals of module are electrically opened.

Note 6. Definition of viewing angle, Refer to figure as below.

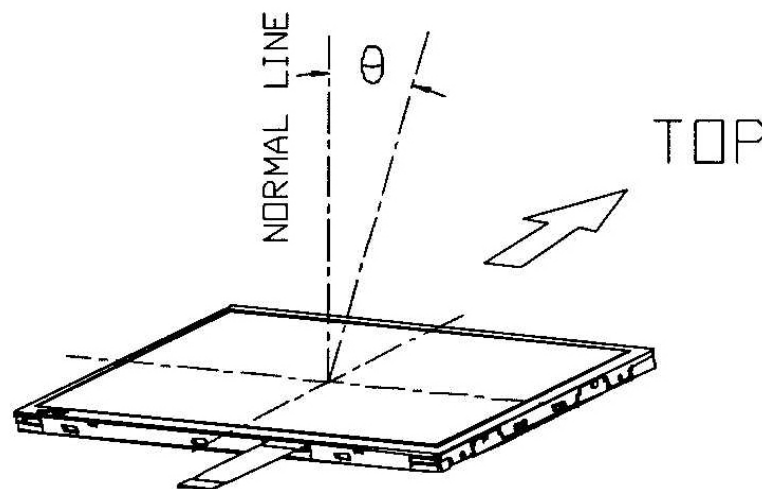

Note 7. Measured at the center area of the panel when all the input terminals of LCD panel are electrically opened.

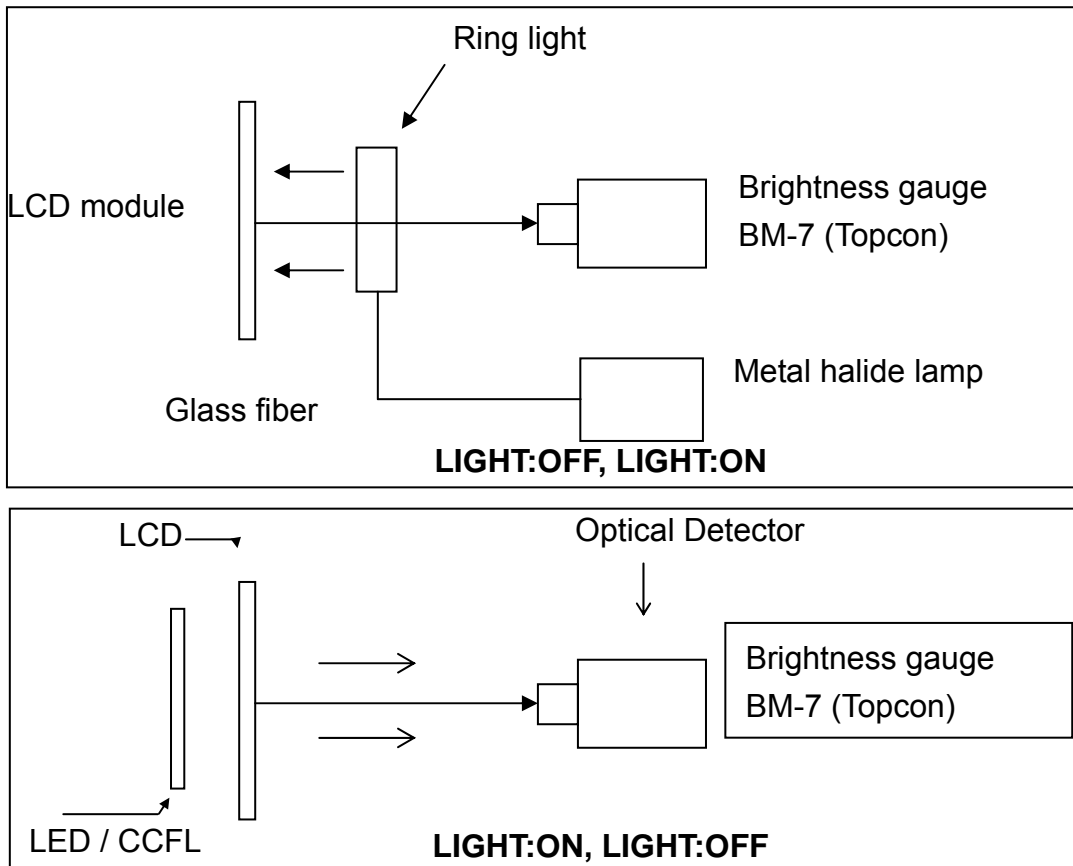

5.2 Optical characteristic of the LED Back-light

ITEM	MIN	TYP	MAX	UNIT	Condition
Bare Brightness	--	3300	--	Cd/m ²	$I_{LED} = 20 \text{ mA}, T_a = 25^\circ\text{C}$
AVG. X of 1931 C.I.E.	(0.26)	(0.29)	(0.32)	--	$I_{LED} = 20 \text{ mA}, T_a = 25^\circ\text{C}$
AVG. X of 1931 C.I.E.	(0.25)	(0.28)	(0.31)	--	$I_{LED} = 20 \text{ mA}, T_a = 25^\circ\text{C}$
Brightness Uniformity	80	--	--	%	$I_{LED} = 20 \text{ mA}, T_a = 25^\circ\text{C}$

() For reference only. These data should be update according the prototype.

Note1 : Measurement after 10 minutes from LED BL operating.

Note2 : Measurement of the following 9 places on the display.

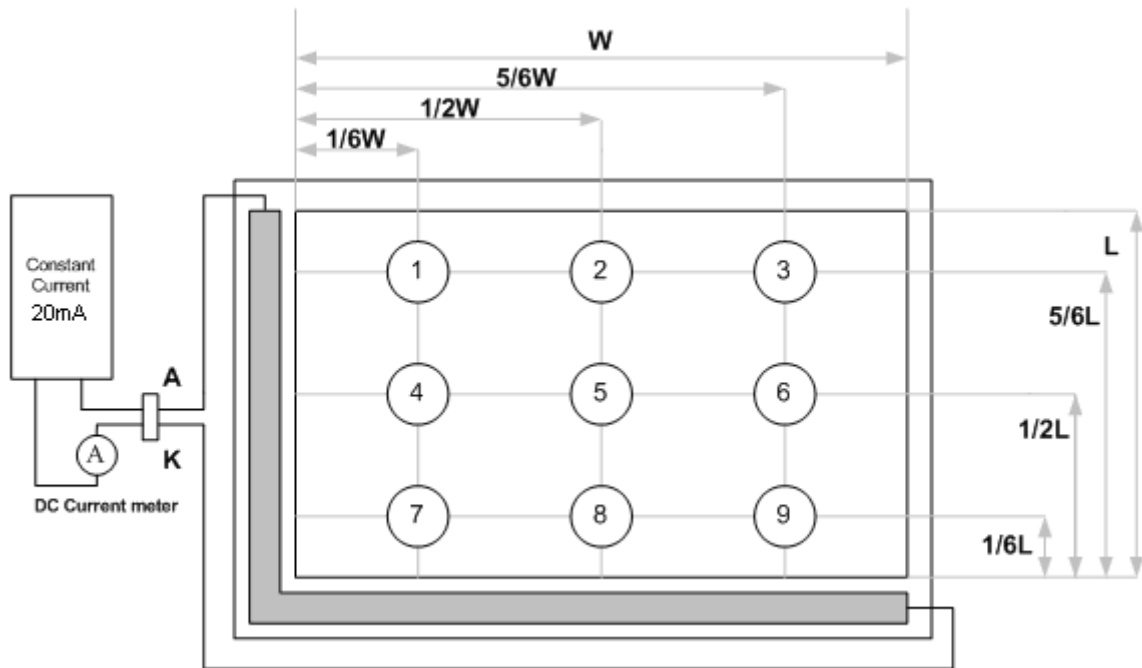

Note3: The Uniformity definition

$(\text{Min Brightness} / \text{Max Brightness}) \times 100\%$

5.3 Touch Panel Electrical Specification

Parameter	Condition	Standard Value
Terminal Resistance	X Axis	500 ~ 1400 Ω
	Y Axis	100 ~ 700 Ω
Insulating Resistance	DC 25 V	More than 20MΩ
Linearity	--	±1.5 %
Notes life by Pen	Note a	100,000 times(min)
Input life by finger	Note b	1,000,000 times (min)

Note A .

Notes area for pen notes life test is 10 x 9 mm.

Size of word is 7.5 x 6.72

Shape of pen end : R0.8

Load : 250 g

Note B

By Silicon rubber tapping at same point

Shape of rubber end : R8

Load : 200g

Frequency : 5 Hz

Interface

No.	Symbol	Function
1	XR	Touch Panel Right Signal in X Axis
2	YD	Touch Panel Bottom Signal in Y Axis
3	XL	Touch Panel Left Signal in X Axis
4	YU	Touch Panel Top Signal in Y Axis

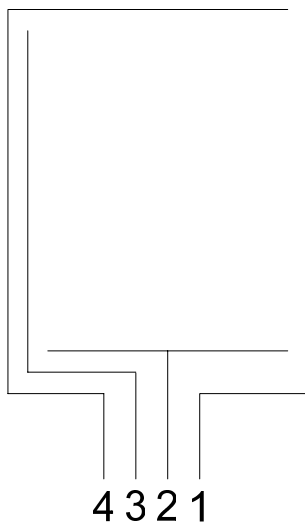

6 Interface specifications

6.1 Driving signals for the TFT panel

Pin no	Symbol	I/O	Description	Remark
1 ~ 2	VSS		GND	
3	LED_A/PWM		Without LED driver	LED Anode
			With LED Driver	PWM
4	LED_K		Without LED driver	LED Cathode
			With LED Driver	Must be OPEN
5	/RESET	I	Reset signal for TFT LCD controller	
6	RS	I	Register and Data select for TFT LCD controller	
7	/CS	I	Chip select low active signal for TFT LCD controller	
8	/WR(E)	I	80mode : /WR low active signal for TFT LCD controller 68mode : E signal latch on rising edge	
9	/RD(R/W)	I	80mode : /RD low active signal for TFT LCD controller 68mode : R/W signal Hi: read Lo:Write	
10 ~ 27	DB0 ~ DB17	I/O	Data Bus	
28	65K/262K	I	Select colors data format H : 262K L : 65K	
29	VSS		GND	
30	SK/X1	-	Serial clock for Touch panel controller Touch Panel Left Signal in X Axis	
31	DO/X2	-	Data Output for Touch panel controller Touch Panel Right Signal in X Axis	
32	DI / Y1	-	Data In for Touch panel controller Touch Panel Upper Signal in Y Axis	
33	TPCS / Y2	-	Chip Select for Touch panel controller Touch Panel Lower Signal in X Axis	
34	IRQ	-	Interrupt for Touch panel controller	
35 ~ 37	VDD		Power supply for the logic (3.3V)	
38 ~ 40	VSS		GND	

30~33 : SK, DO, DI, CS, INT for Touch Panel controller TSC2046
/ X1, X2, Y1, Y2 for Touch Panel (without TSC2046)

7 BLOCK DIAGRAM

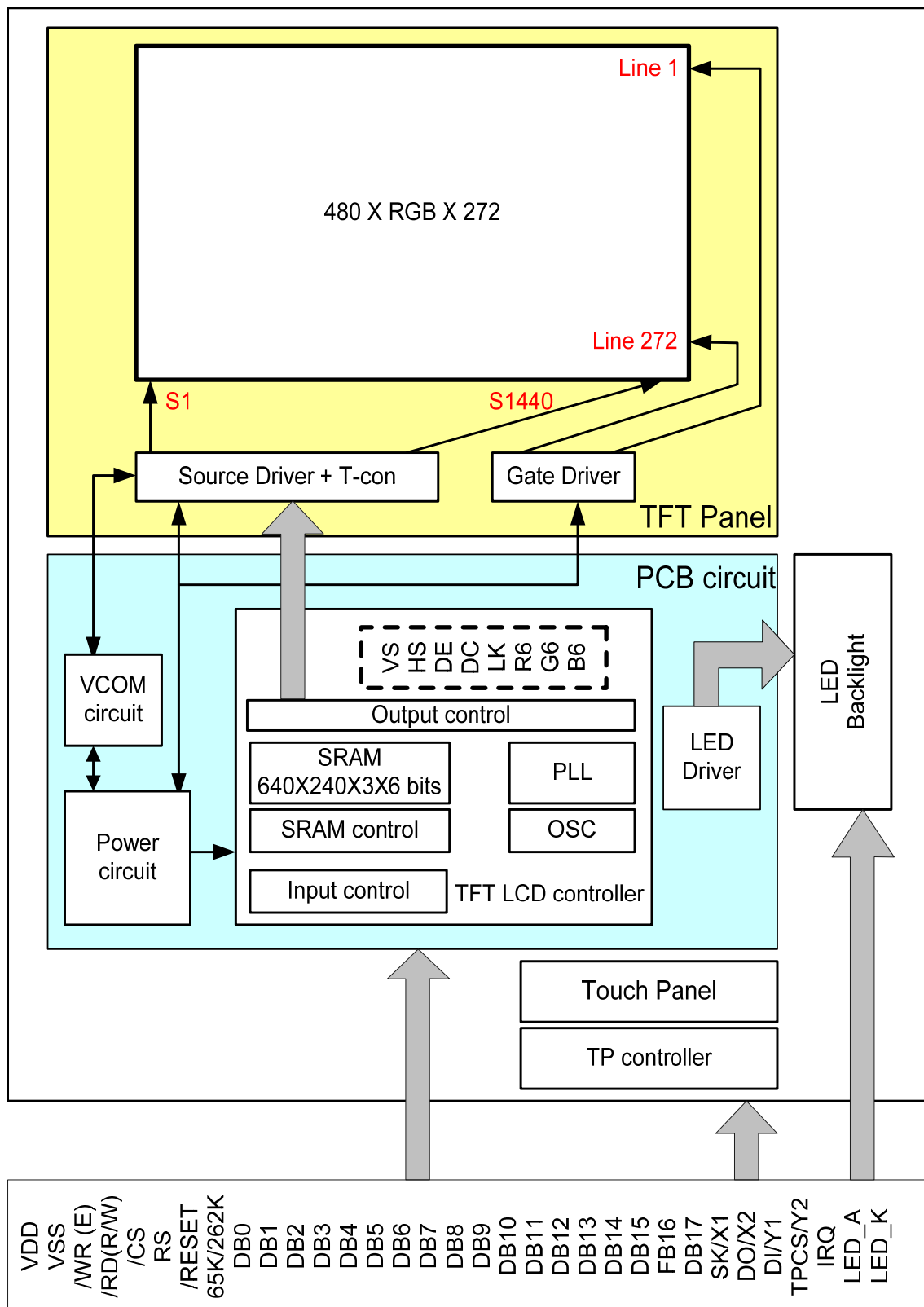

8 Interface Protocol

8.1 18Bit-80/68-Write to Command Register

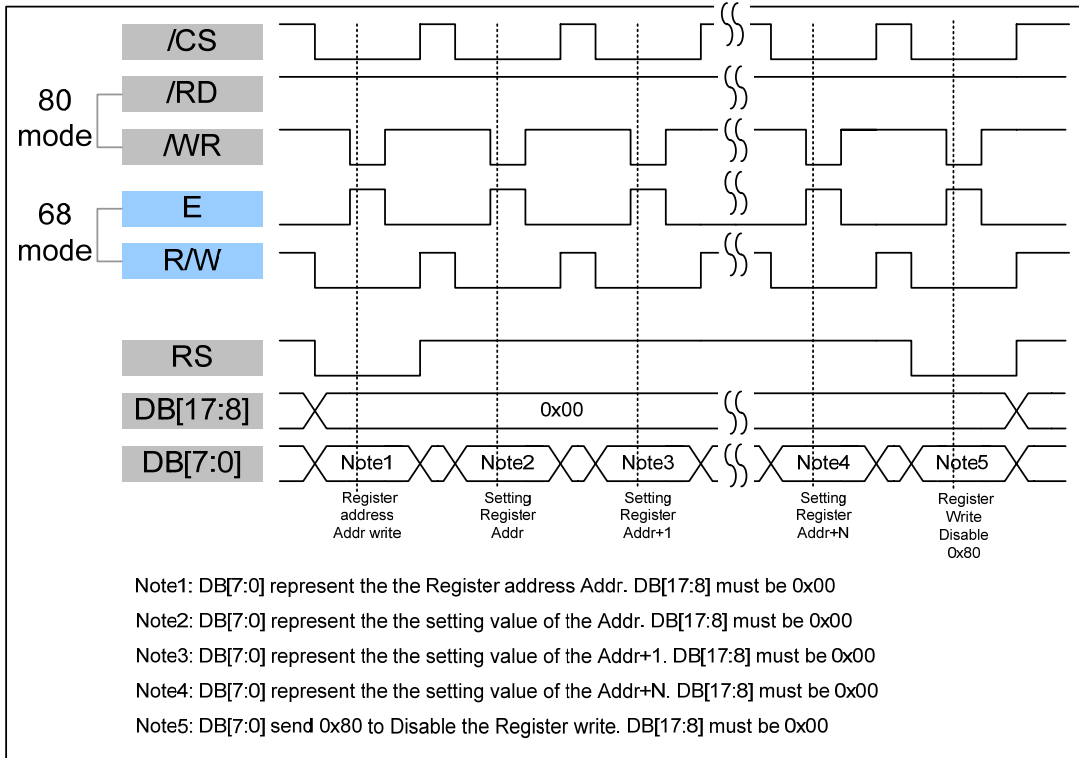

8.2 18Bit-80/68-Write to Display RAM

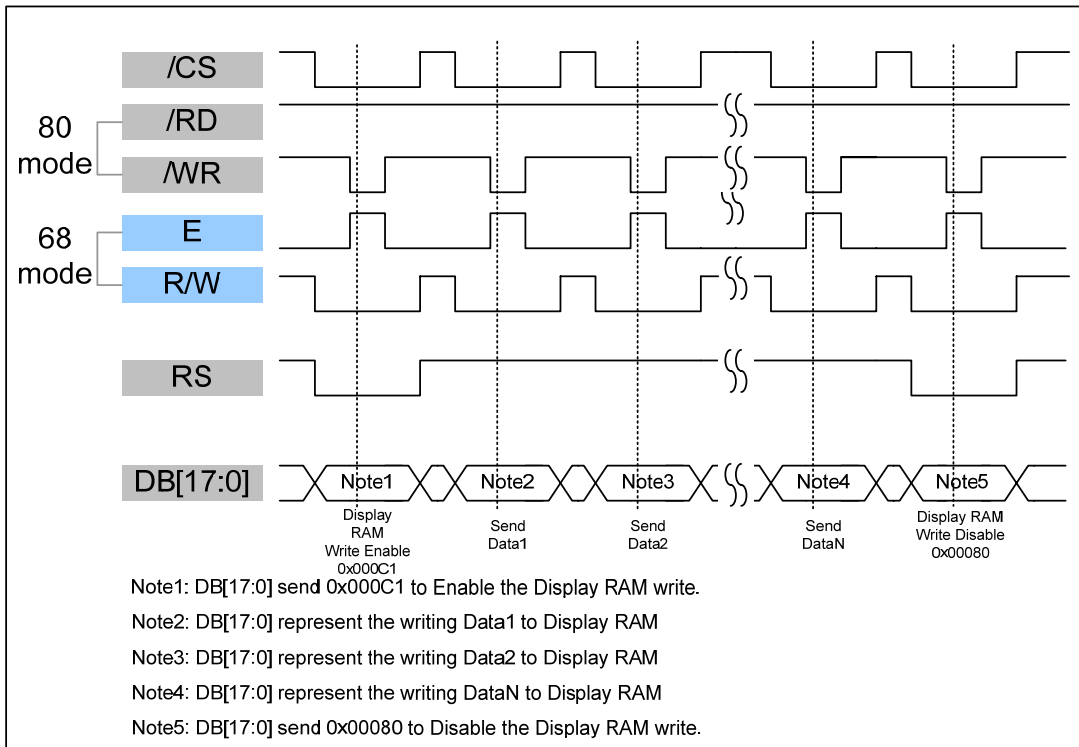

8.3 16Bit-80/68- Write to Command Register

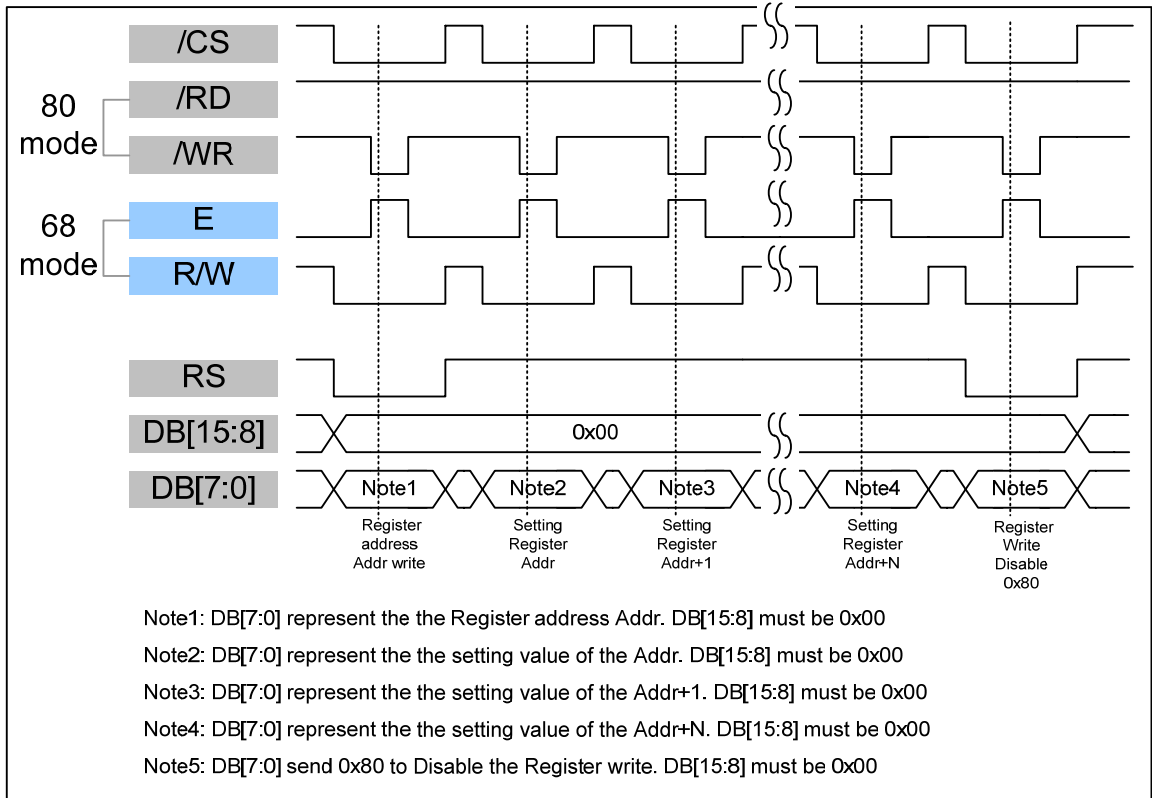

8.4 16Bit-80/68-Write to Display RAM

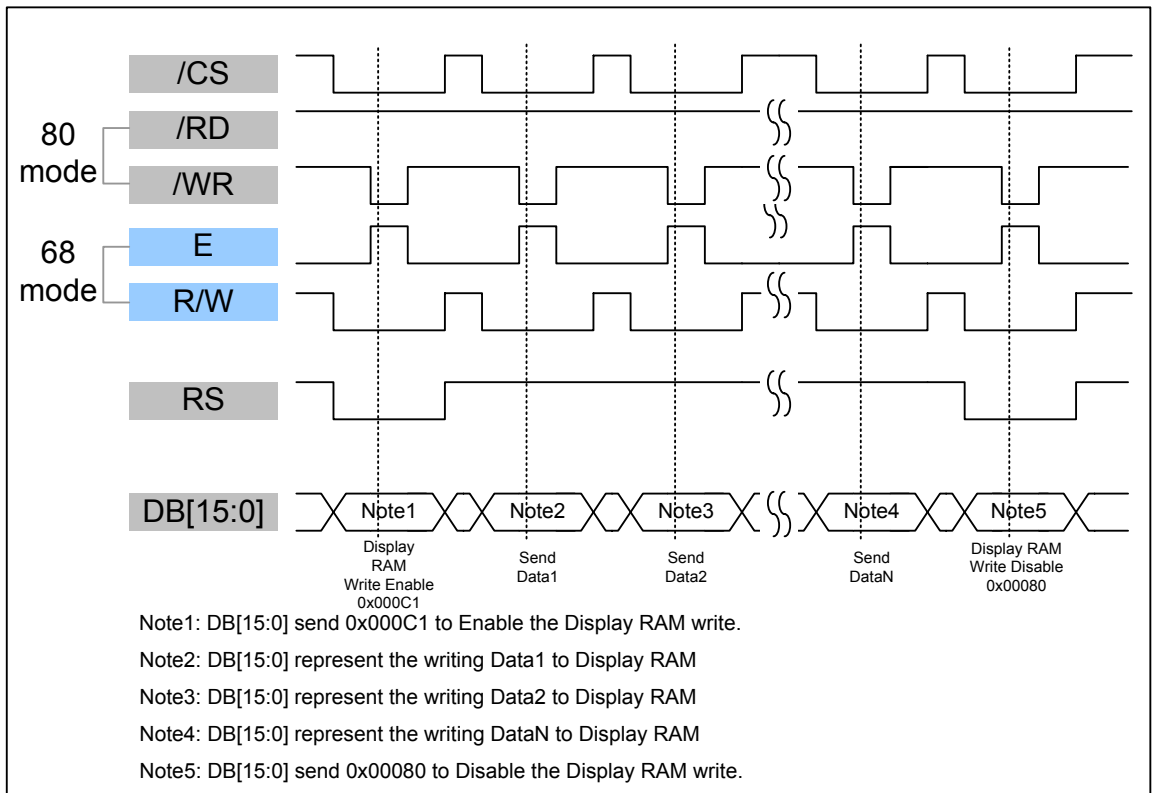

8.5 9Bit-80/68- Write to Command Register

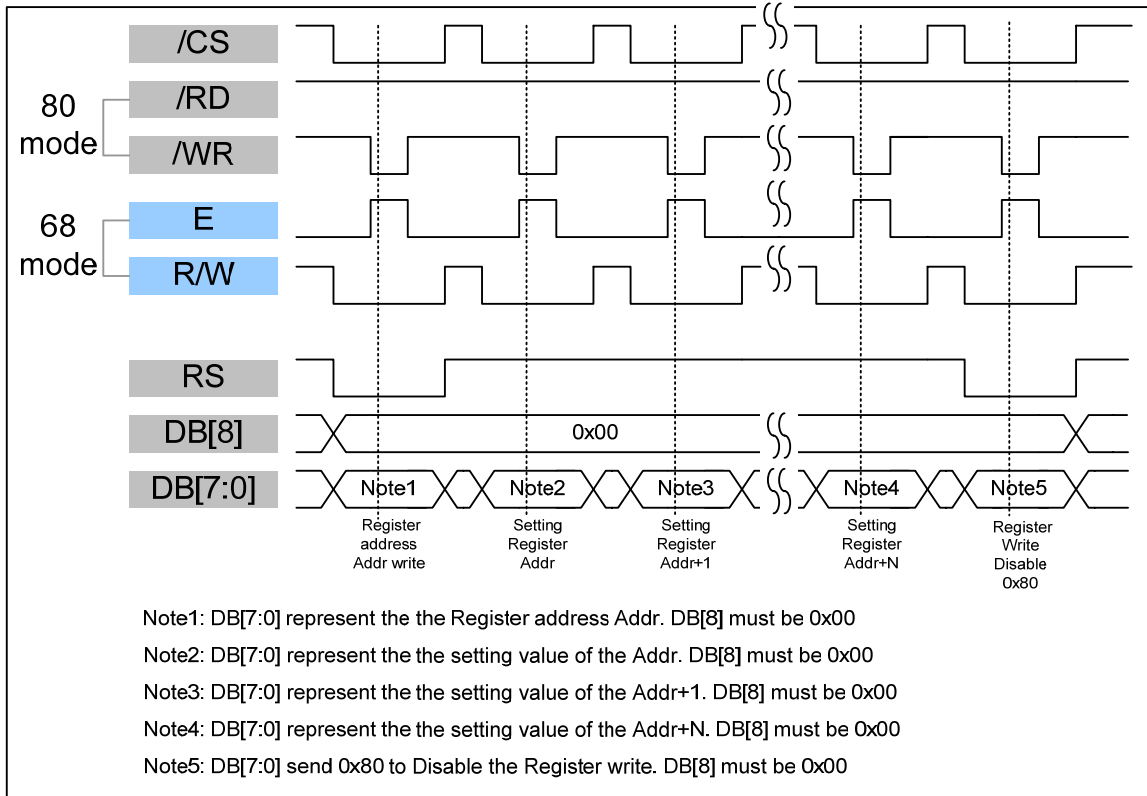

8.6 9Bit-80/68-Write to Display RAM

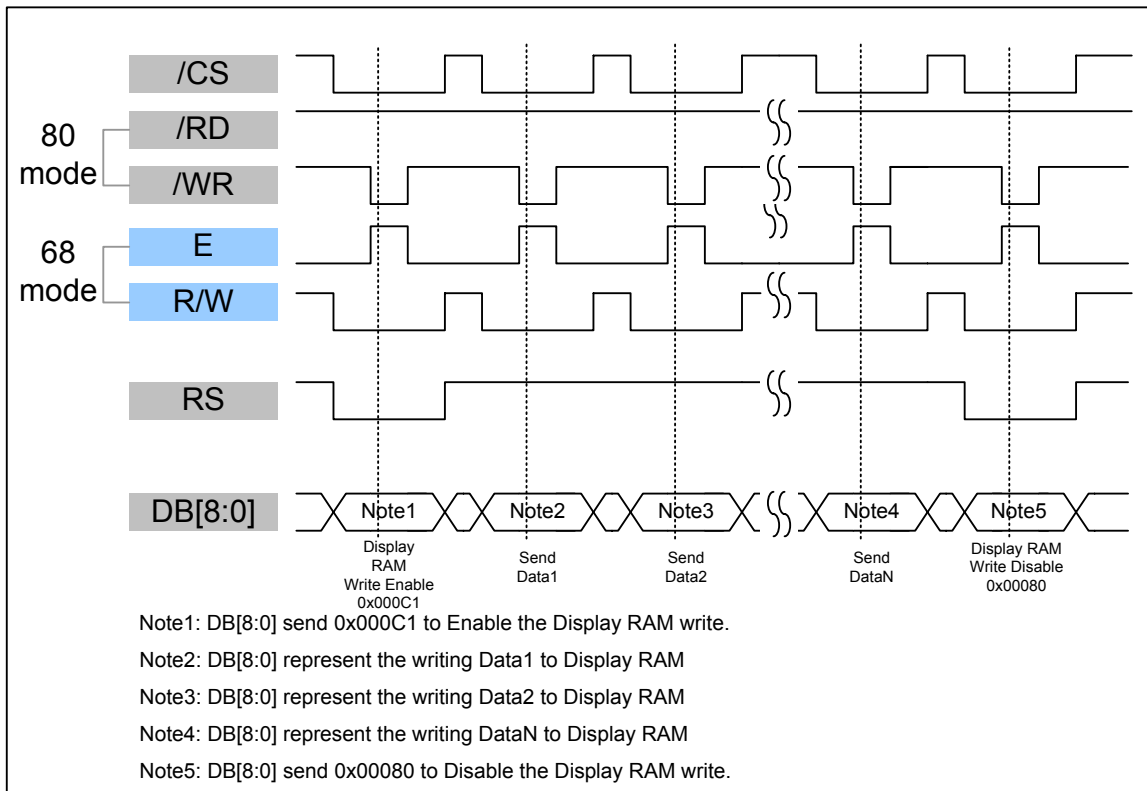

8.7 8Bit-80/68- Write to Command Register

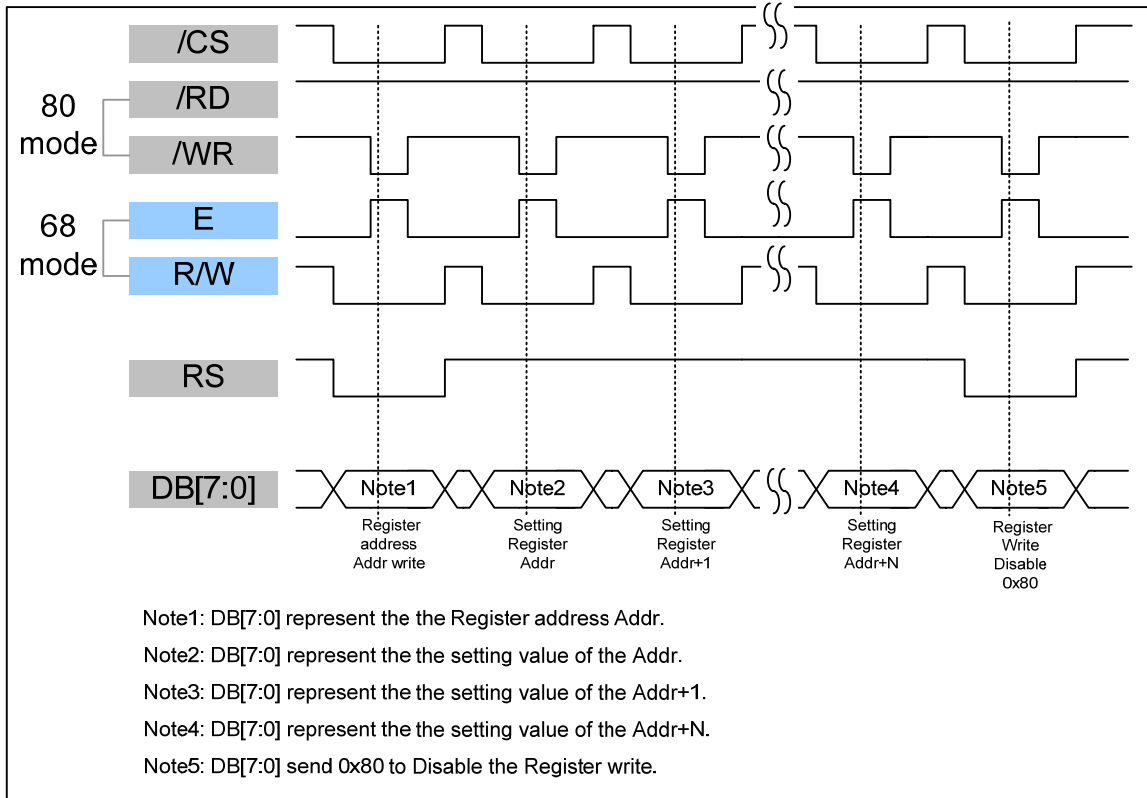

8.8 8Bit-80/68-Write to Display RAM

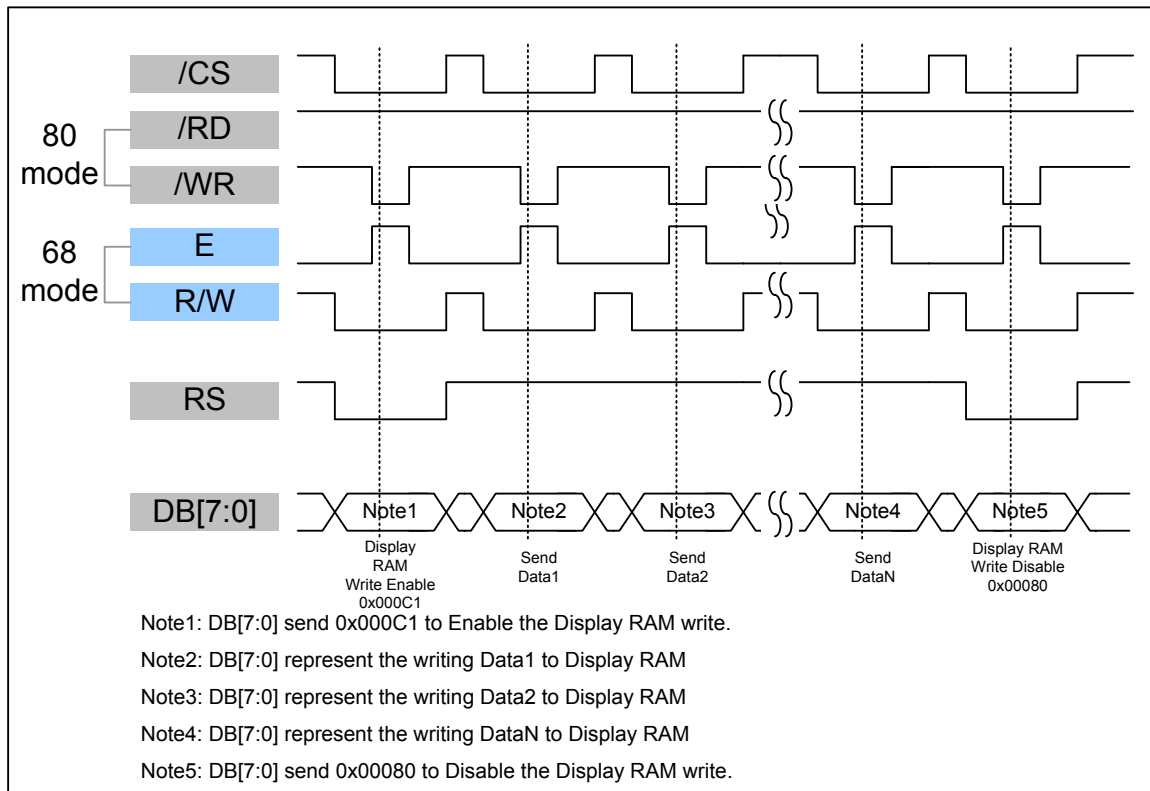

8.9 Data transfer order Setting

8.9.1 18 bit interface 262K color only (Pin28 65K/262K =High)

DB	17	16	15	14	13	12	11	10	9	8	7	6	5	4	3	2	1	0
	R5	R4	R3	R2	R1	R0	G5	G4	G3	G2	G1	G0	B5	B4	B3	B2	B1	B0

8.9.2 16 bit interface 65K color (Pin28 65K/262K =Low)

DB	15	14	13	12	11	10	9	8	7	6	5	4	3	2	1	0
	R4	R3	R2	R1	R0	G5	G4	G3	G2	G1	G0	B4	B3	B2	B1	B0

8.9.3 16 bit interface 262K color (Pin28 65K/262K =High)

DB	15	14	13	12	11	10	9	8	7	6	5	4	3	2	1	0	
1 st data	X	X	X	X	X	X	X	X	X	X	X	X	X	X	X	R5	R4
2 nd data	R3	R2	R1	R0	G5	G4	G3	G2	G1	G0	B5	B4	B3	B2	B1	B0	

8.9.4 9 bit interface 262K color only (Pin28 65K/262K =High)

DB	15	14	13	12	11	10	9	8	7	6	5	4	3	2	1	0
1 st data	X	X	X	X	X	X	X	R5	R4	R3	R2	R1	R0	G5	G4	G3
2 nd data	X	X	X	X	X	X	X	G2	G1	G0	B5	B4	B3	B2	B1	B0

8.9.5 8 bit interface 65K color (Pin28 65K/262K =Low)

DB	15	14	13	12	11	10	9	8	7	6	5	4	3	2	1	0
1 st data	X	X	X	X	X	X	X	X	R4	R3	R2	R1	R0	G5	G4	G3
2 nd data	X	X	X	X	X	X	X	X	G2	G1	G0	B4	B3	B2	B1	B0

8.9.6 8 bit interface 262K color (Pin28 65K/262K =High)

DB	15	14	13	12	11	10	9	8	7	6	5	4	3	2	1	0
1 st data	X	X	X	X	X	X	X	X							R5	R4
2 nd data	X	X	X	X	X	X	X	X	R3	R2	R1	R0	G5	G4	G3	G2
3 rd data	X	X	X	X	X	X	X	X	G1	G0	B5	B4	B3	B2	B1	B0

9 Register Depiction

Register Address (Hex)	Default (Hex)	DB7	DB6	DB5	DB4	DB3	DB2	DB1	DB0	Remark
00	00	MSB of X-axis start position								
Description	set the horizontals start position of display active region									
Register Address (Hex)	Default (Hex)	DB7	DB6	DB5	DB4	DB3	DB2	DB1	DB0	Remark
01	00	LSB of X-axis start position								
Description	set the horizontals start position of display active region									
Register Address (Hex)	Default (Hex)	DB7	DB6	DB5	DB4	DB3	DB2	DB1	DB0	Remark
02	01	MSB of X-axis end position								
Description	set the horizontals end position of display active region									
Register Address (Hex)	Default (Hex)	DB7	DB6	DB5	DB4	DB3	DB2	DB1	DB0	Remark
03	3F	LSB of X-axis end position								
Description	set the horizontals end position of display active region									
Register Address (Hex)	Default (Hex)	DB7	DB6	DB5	DB4	DB3	DB2	DB1	DB0	Remark
04	00	MSB of Y-axis start position								
Description	set the vertical start position of display active region									
Register Address (Hex)	Default (Hex)	DB7	DB6	DB5	DB4	DB3	DB2	DB1	DB0	Remark
05	00	LSB of Y-axis start position								
Description	Set the vertical start position of display active region									
Register Address (Hex)	Default (Hex)	DB7	DB6	DB5	DB4	DB3	DB2	DB1	DB0	Remark
06	00	MSB of Y-axis end position								
Description	set the vertical end position of display active region									
Register Address (Hex)	Default (Hex)	DB7	DB6	DB5	DB4	DB3	DB2	DB1	DB0	Remark
07	EF	LSB of Y-axis end position								
Description	Set the vertical end position of display active region									

To simplify the address control of display RAM access, the window area address function allows for writing data only within a window area of display RAM specified by registers REG[00]~REG[07].

After writing data to the display RAM, the Address counter will be increased within setting window address-range which is specified by

MIN X address (REG[0] & REG[1])

MAX X address (REG[2] & REG[3])

MIN Y address (REG[4] & REG[5])

MAX Y address (REG[6] & REG[7])

Therefore, data can be written consecutively without thinking the data address.

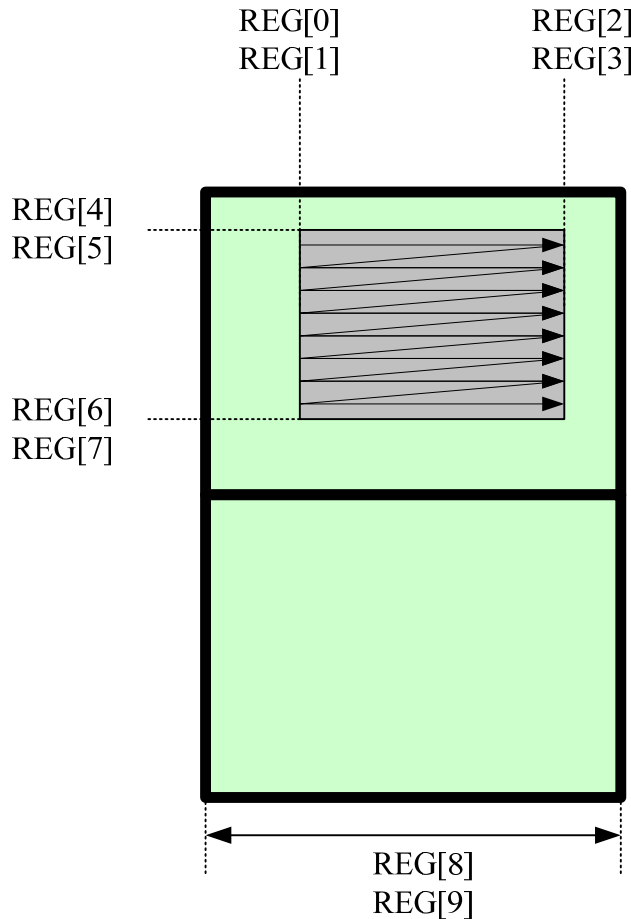

Register Address (Hex)	Default (Hex)	DB7	DB6	DB5	DB4	DB3	DB2	DB1	DB0	Remark
08	01	X	X	X	X	X	X	_PanelXSize H_Byte[1:0]		
Description	Set the panel X size									
Register Address (Hex)	Default (Hex)	DB7	DB6	DB5	DB4	DB3	DB2	DB1	DB0	Remark
09	40	_PanelXSize L_Byte[7:0]								
Description	Set the panel X size									

The register REG[08] and REG[09] is use to calculate the RAM address. If you want to use the TFT as Landscape mode (320x240), the REG[08] & RGE[09] must set to 320. If you want to use the TFT as Portrait mode (240x320), the REG[08] & RGE[09] must set to 240.

Register Address (Hex)	Default (Hex)	DB7	DB6	DB5	DB4	DB3	DB2	DB1	DB0	Remark
0A	00	X	X	X	X	X	[17:16] bits of memory write start address			
Description	Memory write start address									
Register Address (Hex)	Default (Hex)	DB7	DB6	DB5	DB4	DB3	DB2	DB1	DB0	Remark
0B	00	[15:8] bits of memory write start address								
Description	Memory write start address									
Register Address (Hex)	Default (Hex)	DB7	DB6	DB5	DB4	DB3	DB2	DB1	DB0	Remark
0C	00	[7:0] bits of memory write start address								
Description	Memory write start address									

Register Address (Hex)	Default (Hex)	DB7	DB6	DB5	DB4	DB3	DB2	DB1	DB0	Remark
0x10	0x0D	Bit_SWAP	OUT_TEST	BUS_SEL		Blanking	P/S_SEL	CLK_SEL		
Description	"0x10_Clk_sel[1:0]" : The TFT controller built-in 40Mhz PLL clock. These bits are for select the TFT panel dot clock frequency. 00 : 20Mhz 01: 10Mhz 02: 5 Mhz									
	"0x10_ps_sel[2]" : The TFT controller support parallel and serial RGB interface. These bits are for select the output timing. 0 : serial Panel 1: Parallel panel									
	"0x10_blanking_tmp[3]" 0 : OFF (blanking) 1: ON (normal operation)									
	"0x10_bus_sel[5:4]" : It only for serial Panel 00=R , 01=G , 10=B									
	"0x10_out_test[6]" : Self test 0 : normal operation 1: for test (don't use for normal operation) When set the bit to "1" , the Rout=(Reg 2a[6:0]) Gout=(Reg 2b[6:0]) Bout=(Reg 2c[6:0])									
	"0x10_bit_swap[7]" : 0-normal									
	The default setting is suitable for AM320240N1. Don't need to modify it.									
Register Address (Hex)	Default (Hex)	DB7	DB6	DB5	DB4	DB3	DB2	DB1	DB0	Remark
0x11	00	X	X	EVEN			_ODD			
Description	" Even line of serial panel data out sequence or data bus order of parallel panel 000: RGB									

001: RBG 010: GRB 011: GBR 100: BRG 101: BGR Others: reserved Odd line of serial panel data out sequence 000: RGB 001: RBG 010: GRB 011: GBR 100: BRG 101: BGR Others: reserved Must Set to 0x05 for AM320240N1

Register Address (Hex)	Default (Hex)	DB7	DB6	DB5	DB4	DB3	DB2	DB1	DB0	Remark	
0x12	00					Hsync_stH_Byte[3:0]					
Description	For TFT output timing adjust: Hsync start position H-Byte The default setting is suitable for AM320240N1. Don't need to modify it.										
Register Address (Hex)	Default (Hex)	DB7	DB6	DB5	DB4	DB3	DB2	DB1	DB0	Remark	
0x13	00	Hsync_stL_Byte[7:0]									
Description	For TFT output timing adjust: Hsync start position L-Byte The default setting is suitable for AM320240N1. Don't need to modify it.										
Register Address (Hex)	Default (Hex)	DB7	DB6	DB5	DB4	DB3	DB2	DB1	DB0	Remark	
0x14	00					Hsync_pwH_Byte[3:0]					
Description	For TFT output timing adjust: Hsync pulse width H-Byte The default setting is suitable for AM320240N1. Don't need to modify it.										
Register Address (Hex)	Default (Hex)	DB7	DB6	DB5	DB4	DB3	DB2	DB1	DB0	Remark	
0x15	10	Hsync_pwL_Byte[7:0]									
Description	For TFT output timing adjust: Hsync pulse width L-Byte The default setting is suitable for AM320240N1. Don't need to modify it.										
Register Address (Hex)	Default (Hex)	DB7	DB6	DB5	DB4	DB3	DB2	DB1	DB0	Remark	
0x16	00					Hact_stH_Byte[3:0]					

Description	For TFT output timing adjust: DE pulse start position H-Byte The default setting is suitable for AM320240N1. Don't need to modify it.									
Register Address (Hex)	Default (Hex)	DB7	DB6	DB5	DB4	DB3	DB2	DB1	DB0	Remark
0x17	38	Hact_stL_Byte[7:0]								
Description	For TFT output timing adjust: DE pulse start position L-Byte The default setting is suitable for AM320240N1. Don't need to modify it.									
Register Address (Hex)	Default (Hex)	DB7	DB6	DB5	DB4	DB3	DB2	DB1	DB0	Remark
0x18	01					Hact_pwH_Byte[3:0]				
Description	For TFT output timing adjust: DE pulse width H-Byte The default setting is suitable for AM320240N1. Don't need to modify it.									
Register Address (Hex)	Default (Hex)	DB7	DB6	DB5	DB4	DB3	DB2	DB1	DB0	Remark
0x19	40	Hact_pwL_Byte[7:0]								
Description	For TFT output timing adjust: DE pulse width L-Byte The default setting is suitable for AM320240N1. Don't need to modify it.									

Register Address (Hex)	Default (Hex)	DB7	DB6	DB5	DB4	DB3	DB2	DB1	DB0	Remark
0x1A	01					HtotalH_Byte[3:0]				
Description	For TFT output timing adjust: Hsync total clocks H-Byte The default setting is suitable for AM320240N1. Don't need to modify it.									
Register Address (Hex)	Default (Hex)	DB7	DB6	DB5	DB4	DB3	DB2	DB1	DB0	Remark
0x1B	B8	HtotalL_Byte[7:0]								
Description	For TFT output timing adjust: Hsync total clocks H-Byte The default setting is suitable for AM320240N1. Don't need to modify it.									
Register Address (Hex)	Default (Hex)	DB7	DB6	DB5	DB4	DB3	DB2	DB1	DB0	Remark
0x1C	00					Vsync_stH_Byte[3:0]				
Description	For TFT output timing adjust: Vsync start position H-Byte The default setting is suitable for AM320240N1. Don't need to modify it.									

Register Address (Hex)	Default (Hex)	DB7	DB6	DB5	DB4	DB3	DB2	DB1	DB0	Remark
0x1D	00	Vsync_stL_Byte[7:0]								
Description	For TFT output timing adjust: Vsync start position L-Byte The default setting is suitable for AM320240N1. Don't need to modify it.									
Register Address (Hex)	Default (Hex)	DB7	DB6	DB5	DB4	DB3	DB2	DB1	DB0	Remark
0x1E	00	Vsync_pwH_Byte[3:0]								
Description	For TFT output timing adjust: Vsync pulse width H-Byte The default setting is suitable for AM320240N1. Don't need to modify it.									
Register Address (Hex)	Default (Hex)	DB7	DB6	DB5	DB4	DB3	DB2	DB1	DB0	Remark
0x1F	08	Vsync_pwL_Byte[7:0]								
Description	For TFT output timing adjust: Vsync pulse width L-Byte The default setting is suitable for AM320240N1. Don't need to modify it.									
Register Address (Hex)	Default (Hex)	DB7	DB6	DB5	DB4	DB3	DB2	DB1	DB0	Remark
0x20	00	Vact_stH_Byte[3:0]								
Description	For TFT output timing adjust: Vertical DE pulse start position H-Byte The default setting is suitable for AM320240N1. Don't need to modify it.									
Register Address (Hex)	Default (Hex)	DB7	DB6	DB5	DB4	DB3	DB2	DB1	DB0	Remark
0x21	12	Vact_stL_Byte[7:0]								
Description	For TFT output timing adjust: Vertical DE pulse start position L-Byte The default setting is suitable for AM320240N1. Don't need to modify it.									
Register Address (Hex)	Default (Hex)	DB7	DB6	DB5	DB4	DB3	DB2	DB1	DB0	Remark
0x22	00	Vact_pwH_Byte[3:0]								
Description	For TFT output timing adjust: Vertical Active width H-Byte The default setting is suitable for AM320240N1. Don't need to modify it.									
Register Address (Hex)	Default (Hex)	DB7	DB6	DB5	DB4	DB3	DB2	DB1	DB0	Remark
0x23	F0	Vact_pwL_Byte[7:0]								
Description	For TFT output timing adjust: Vertical Active width H-Byte The default setting is suitable for AM320240N1. Don't need to modify it.									

Register Address (Hex)	Default (Hex)	DB7	DB6	DB5	DB4	DB3	DB2	DB1	DB0	Remark
0x24	01									VtotalH_Byte[3:0]
Description	For TFT output timing adjust: Vertical total width H-Byte The default setting is suitable for AM320240N1. Don't need to modify it.									
Register Address (Hex)	Default (Hex)	DB7	DB6	DB5	DB4	DB3	DB2	DB1	DB0	Remark
0x25	09									VtotalL_Byte[7:0]
Description	For TFT output timing adjust: Vertical total width L-Byte The default setting is suitable for AM320240N1. Don't need to modify it.									

Register Address (Hex)	Default (Hex)	DB7	DB6	DB5	DB4	DB3	DB2	DB1	DB0	Remark
26	00	X	X	X	X	X				[17:16] bits of memory read start address
Description	Memory read start address									
Register Address (Hex)	Default (Hex)	DB7	DB6	DB5	DB4	DB3	DB2	DB1	DB0	Remark
27	00									[15:8] bits of memory write start address
Description	Memory read start address									
Register Address (Hex)	Default (Hex)	DB7	DB6	DB5	DB4	DB3	DB2	DB1	DB0	Remark
28	00									[7:0] bits of memory write start address
Description	Memory read start address									

Register Address (Hex)	Default (Hex)	DB7	DB6	DB5	DB4	DB3	DB2	DB1	DB0	Remark
29	00									[7:1] Reversed
Description	[0] Load output timing related setting (H sync., V sync. and DE) to take effect									

Register Address (Hex)	Default (Hex)	DB7	DB6	DB5	DB4	DB3	DB2	DB1	DB0	Remark
0x2A	00	X								TestPatternRout[6:0]
Description	When " REG[0x10]_out_test[6]" : Self test =1 ; The Rout data equal to TestPatternRout[6:0]									

Register Address (Hex)	Default (Hex)	DB7	DB6	DB5	DB4	DB3	DB2	DB1	DB0	Remark
0x2B	00	X	TestPatternGout[6:0]							
Description	When " REG[0x10]_out_test[6]" : Self test =1 ; The Gout data equal to TestPatternGout[6:0]									
Register Address (Hex)	Default (Hex)	DB7	DB6	DB5	DB4	DB3	DB2	DB1	DB0	Remark
0x2C	00	X	TestPatternBout[6:0]							
Description	When " REG[0x10]_out_test[6]" : Self test =1 ; The Bout data equal to TestPatternBout[6:0]									

If you set the " REG[0x10]_out_test[6]" : Self test =1 , the TFT controller will skip the connect of the display RAM. The Output port will send the REG[2A] ,REG[2B],REG[2C] data.

REG[2A]=0x3F
REG[2B]=0x00
REG[2C]=0x00

REG[2A]=0x00
REG[2B]=0x3F
REG[2C]=0x00

REG[2A]=0x00
REG[2B]=0x00
REG[2C]=0x3F

Register Address (Hex)	Default (Hex)	DB7	DB6	DB5	DB4	DB3	DB2	DB1	DB0	Remark
0x2D	00	X	X	X	X	[3]	Rising/falling edge[2]	_rotate [1:0]		
Description	[3] Output pin X_DCON level control ; TFT Power ON/OFF control 0: TFT POWER circuit OFF 1: TFT POWER circuit ON									
	Rising/falling edge[2] : 0: The RGB out put data are on the Rising edge of the DCLK. 1: The RGB out put data are on the Falling edge of the DCLK.									
	_rotate [1:0]: 00 : rotate 0 degree 01 : rotate 90 degree 10 : rotate 270 degree 11 : rotate 180 degree									

Register Address (Hex)	Default (Hex)	DB7	DB6	DB5	DB4	DB3	DB2	DB1	DB0	Remark
30	00	X	X	X	X	X	_H byte H-Offset[3:0]			
Description	Set the Horizontal offset									

Register Address (Hex)	Default (Hex)	DB7	DB6	DB5	DB4	DB3	DB2	DB1	DB0	Remark
31	00	_L byte H-Offset[7:0]								
Description	Set the Horizontal offset									

Register Address (Hex)	Default (Hex)	DB7	DB6	DB5	DB4	DB3	DB2	DB1	DB0	Remark
32	00	X	X	X	X	X	_H byte V-Offset[3:0]			
Description	Set the Vertical offset									

Register Address (Hex)	Default (Hex)	DB7	DB6	DB5	DB4	DB3	DB2	DB1	DB0	Remark
33	00	_L byte V-Offset[7:0]								
Description	Set the Vertical offset									

Register Address (Hex)	Default (Hex)	DB7	DB6	DB5	DB4	DB3	DB2	DB1	DB0	Remark	
34	00	[7:4] Reserved					_H byte H-def[3:0]				
Description	[3:0] MSB of image horizontal physical resolution in memory										

Register Address (Hex)	Default (Hex)	DB7	DB6	DB5	DB4	DB3	DB2	DB1	DB0	Remark
35	40	_L byte H-def[7:0]								
Description	[7:0] LSB of image horizontal physical resolution in memory									

Register Address (Hex)	Default (Hex)	DB7	DB6	DB5	DB4	DB3	DB2	DB1	DB0	Remark	
36	01	[7:4] Reserved					_H byte V-def[3:0]				
Description	[3:0] MSB of image vertical physical resolution in memory										

Register Address (Hex)	Default (Hex)	DB7	DB6	DB5	DB4	DB3	DB2	DB1	DB0	Remark
37	E0	_L byte V-def[7:0]								
Description	[7:0] LSB of image vertical physical resolution in memory									

The total RAM size is 640x240x18bit. The user can arrange the Horizontal ram size by REG[34],REG[35] and the Vertical ram size by REG[36],REG[37].

EX: 320x480x18bit REG[34]=0x01 , REG[35]=0x40 , REG[36]=0x01 , REG[37]=0xE0

EX: 640x240x18bit. REG[34]=0x02 , REG[35]=0x80 , REG[36]=0x00 , REG[37]=0xF0

DISPLAYED COLOR AND INPUT DATA

	Color & Gray Scale	DATA SIGNAL																	
		R5	R4	R3	R2	R1	R0	G5	G4	G3	G2	G1	G0	B5	B4	B3	B2	B1	B0
Basic Color	Black	0	0	0	0	0	0	0	0	0	0	0	0	0	0	0	0	0	0
	Red(0)	1	1	1	1	1	1	0	0	0	0	0	0	0	0	0	0	0	0
	Green(0)	0	0	0	0	0	0	1	1	1	1	1	1	0	0	0	0	0	0
	Blue(0)	0	0	0	0	0	0	0	0	0	0	0	0	1	1	1	1	1	1
	Cyan	0	0	0	0	0	0	1	1	1	1	1	1	1	1	1	1	1	1
	Magenta	1	1	1	1	1	1	0	0	0	0	0	0	1	1	1	1	1	1
	Yellow	1	1	1	1	1	1	1	1	1	1	1	1	0	0	0	0	0	0
	White	1	1	1	1	1	1	1	1	1	1	1	1	1	1	1	1	1	1
Red	Black	0	0	0	0	0	0	0	0	0	0	0	0	0	0	0	0	0	0
	Red(62)	0	0	0	0	0	1	0	0	0	0	0	0	0	0	0	0	0	0
	Red(61)	0	0	0	0	1	0	0	0	0	0	0	0	0	0	0	0	0	0
	:	:	:	:	:	:	:	:	:	:	:	:	:	:	:	:	:	:	:
	Red(31)	0	1	1	1	1	1	0	0	0	0	0	0	0	0	0	0	0	0
	:	:	:	:	:	:	:	:	:	:	:	:	:	:	:	:	:	:	:
	Red(1)	1	1	1	1	1	0	0	0	0	0	0	0	0	0	0	0	0	0
	Red(0)	1	1	1	1	1	1	0	0	0	0	0	0	0	0	0	0	0	0
Green	Black	0	0	0	0	0	0	0	0	0	0	0	0	0	0	0	0	0	0
	Green(62)	0	0	0	0	0	0	0	0	0	0	1	0	0	0	0	0	0	0
	Green(61)	0	0	0	0	0	0	0	0	0	0	1	0	0	0	0	0	0	0
	:	:	:	:	:	:	:	:	:	:	:	:	:	:	:	:	:	:	:
	Green(31)	0	0	0	0	0	0	0	1	1	1	1	0	0	0	0	0	0	0
	:	:	:	:	:	:	:	:	:	:	:	:	:	:	:	:	:	:	:
	Green(1)	0	0	0	0	0	0	1	1	1	1	1	0	0	0	0	0	0	0
	Green(0)	0	0	0	0	0	0	1	1	1	1	1	1	0	0	0	0	0	0
Blue	Black	0	0	0	0	0	0	0	0	0	0	0	0	0	0	0	0	0	0
	Blue(62)	0	0	0	0	0	0	0	0	0	0	0	0	0	0	0	0	0	1
	Blue(61)	0	0	0	0	0	0	0	0	0	0	0	0	0	0	0	0	1	0
	:	:	:	:	:	:	:	:	:	:	:	:	:	:	:	:	:	:	:
	Blue(31)	0	0	0	0	0	0	0	0	0	0	0	0	0	1	1	1	1	1
	:	:	:	:	:	:	:	:	:	:	:	:	:	:	:	:	:	:	:
	Blue(1)	0	0	0	0	0	0	0	0	0	0	0	0	1	1	1	1	1	0
	Blue(0)	0	0	0	0	0	0	0	0	0	0	0	0	1	1	1	1	1	1

10 QUALITY AND RELIABILITY

10.1 TEST CONDITIONS

Tests should be conducted under the following conditions :

Ambient temperature : $25 \pm 5^{\circ}\text{C}$

Humidity : $60 \pm 25\% \text{ RH.}$

10.2 SAMPLING PLAN

Sampling method shall be in accordance with MIL-STD-105E , level II, normal single sampling plan .

10.3 ACCEPTABLE QUALITY LEVEL

A major defect is defined as one that could cause failure to or materially reduce the usability of the unit for its intended purpose. A minor defect is one that does not materially reduce the usability of the unit for its intended purpose or is an infringement from established standards and has no significant bearing on its effective use or operation.

10.4 APPEARANCE

An appearance test should be conducted by human sight at approximately 30 cm distance from the LCD module under flourescent light. The inspection area of LCD panel shall be within the range of following limits.

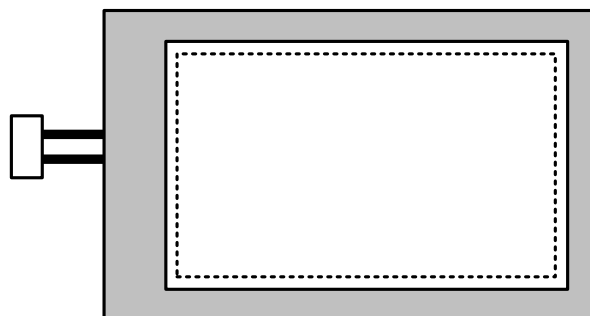

⋯ Zone A (Active Area)

□ Zone B (Viewing Area)

10.5 INSPECTION QUALITY CRITERIA

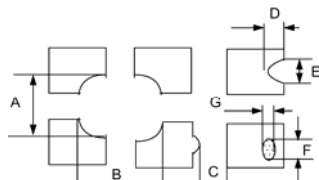
No.	Item	Criterion for defects	Class of Defect	Acceptable level										
1	Non display	No non display is allowed	Major	0.4										
2	Irregular operation	No irregular operation is allowed	Major	0.4										
3	Short	No short are allowed	Major	0.4										
4	Open	Any segments or common patterns that don't activate are rejectable.	Major	0.4										
5	Black/White spot (l)	<table border="1" style="width: 100%; border-collapse: collapse;"> <thead> <tr> <th style="text-align: center;">Size D (mm)</th> <th style="text-align: center;">Acceptable number</th> </tr> </thead> <tbody> <tr> <td style="text-align: center;">$D \leq 0.1$</td> <td style="text-align: center;">Ignore</td> </tr> <tr> <td style="text-align: center;">$0.1 < D \leq 0.15$</td> <td style="text-align: center;">2 ※1</td> </tr> <tr> <td style="text-align: center;">$0.15 < D$</td> <td style="text-align: center;">0</td> </tr> </tbody> </table> <p>※1: The distance of two defects must be more than 20mm.</p>	Size D (mm)	Acceptable number	$D \leq 0.1$	Ignore	$0.1 < D \leq 0.15$	2 ※1	$0.15 < D$	0	Minor	1.5		
Size D (mm)	Acceptable number													
$D \leq 0.1$	Ignore													
$0.1 < D \leq 0.15$	2 ※1													
$0.15 < D$	0													
6	Dot Defect	<table border="1" style="width: 100%; border-collapse: collapse;"> <tbody> <tr> <td style="text-align: center;">Bright dot</td> <td style="text-align: center;">1</td> </tr> <tr> <td style="text-align: center;">Dark dot</td> <td style="text-align: center;">$N \leq 3$</td> </tr> <tr> <td style="text-align: center;">Total dot defect (Bright dot + Dark dot)</td> <td style="text-align: center;">$N \leq 4$</td> </tr> <tr> <td style="text-align: center;">Minimum distance between dark dot and dark dot</td> <td style="text-align: center;">$0.1 < D \leq 0.3\text{mm}, N \leq 2$</td> </tr> </tbody> </table>	Bright dot	1	Dark dot	$N \leq 3$	Total dot defect (Bright dot + Dark dot)	$N \leq 4$	Minimum distance between dark dot and dark dot	$0.1 < D \leq 0.3\text{mm}, N \leq 2$	Minor	1.5		
Bright dot	1													
Dark dot	$N \leq 3$													
Total dot defect (Bright dot + Dark dot)	$N \leq 4$													
Minimum distance between dark dot and dark dot	$0.1 < D \leq 0.3\text{mm}, N \leq 2$													
7	Back Light	1. No Lighting is rejectable 2. Flickering and abnormal lighting are rejectable	Major	0.4										
8	Display pattern	 <table border="1" style="width: 100%; border-collapse: collapse;"> <tbody> <tr> <td style="text-align: center;">$\frac{A+B}{2} \leq 0.30$</td> <td style="text-align: center;">$0 < C$</td> <td style="text-align: center;">$\frac{D+E}{2} \leq 0.25$</td> <td style="text-align: center;">$\frac{F+G}{2} \leq 0.25$</td> </tr> </tbody> </table> <p>Note: 1. Acceptable up to 3 damages 2. NG if there're two or more pinholes per dot</p>	$\frac{A+B}{2} \leq 0.30$	$0 < C$	$\frac{D+E}{2} \leq 0.25$	$\frac{F+G}{2} \leq 0.25$	Minor	1.5						
$\frac{A+B}{2} \leq 0.30$	$0 < C$	$\frac{D+E}{2} \leq 0.25$	$\frac{F+G}{2} \leq 0.25$											
9	Blemish & Foreign matters Size: $D = \frac{A+B}{2}$	<table border="1" style="width: 100%; border-collapse: collapse;"> <thead> <tr> <th style="text-align: center;">Size D (mm)</th> <th style="text-align: center;">Acceptable number</th> </tr> </thead> <tbody> <tr> <td style="text-align: center;">$D \leq 0.15$</td> <td style="text-align: center;">Ignore</td> </tr> <tr> <td style="text-align: center;">$0.15 < D \leq 0.20$</td> <td style="text-align: center;">3</td> </tr> <tr> <td style="text-align: center;">$0.20 < D \leq 0.30$</td> <td style="text-align: center;">2</td> </tr> <tr> <td style="text-align: center;">$0.30 < D$</td> <td style="text-align: center;">0</td> </tr> </tbody> </table>	Size D (mm)	Acceptable number	$D \leq 0.15$	Ignore	$0.15 < D \leq 0.20$	3	$0.20 < D \leq 0.30$	2	$0.30 < D$	0	Minor	1.5
Size D (mm)	Acceptable number													
$D \leq 0.15$	Ignore													
$0.15 < D \leq 0.20$	3													
$0.20 < D \leq 0.30$	2													
$0.30 < D$	0													

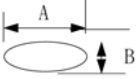
10	Scratch on Polarizer 	Width (mm)	Length (mm)	Acceptable number	Minor	1.5
		$W \leq 0.03$	$L \leq 2.0$	2		
		Note: The distance of two defects must be more than 20mm.				
11	Bubble in polarizer	Zone A Active area : No bubble are allowed. Zone B Viewing area: $\leq 0.05\text{mm}^2$, $N \leq 1$			Minor	1.5
12	Stains on LCD panel surface	Stains that cannot be removed even when wiped lightly with a soft cloth or similar cleaning too are rejectable.			Minor	1.5
13	Rust in Bezel	Rust which is visible in the bezel is rejectable.			Minor	1.5
14	Defect of land surface contact (poor soldering)	Evident crevices which is visible are rejectable.			Minor	1.5
15	Parts mounting	1. Failure to mount parts 2. Parts not in the specifications are mounted 3. Polarity, for example, is reversed			Major Major Major	0.4
16	Parts alignment	1. LSI, IC lead width is more than 50% beyond pad outline.			Minor	1.5
		2. Chip component is off center and more than 50% of the leads is off the pad outline.			Minor	
17	Conductive foreign matter (Solder ball, Solder chips)	1. $0.45 < \varphi$, $N \geq 1$			Major	0.4
		2. $0.30 < \varphi \leq 0.45$, $N \geq 1$ φ : Average diameter of solder ball (unit: mm)			Minor	1.5
		3. $0.50 < L$, $N \geq 1$ L: Average length of solder chip (unit: mm)			Minor	1.5
18	Faulty PCB correction	1. Due to PCB copper foil pattern burnout, the pattern is connected, using a jumper wire for repair; 2 or more places are corrected per PCB.			Minor	1.5
		2. Short circuited part is cut, and no resist coating has been performed.			Minor	

11 RELIABILITY TEST CONDITIONS

ITEM	CONDITIONS	NOTE
HIGH TEMPERATURE OPERATION	70°C , 240Hrs	
HIGH TEMPERATURE AND HIGH HUMIDITY OPERATION	60°C , 90%RH , 240Hrs	
HIGH TEMPERATURE STORAGE	80°C , 240Hrs	
LOW TEMPERATURE OPERATION	-20°C , 240Hrs	
LOW TEMPERATURE STORAGE	-30°C , 240Hrs	
THERMAL SHOCK	-30°C(1Hr) ~80°C(1Hr) 200Cycle	

12 USE PRECAUTIONS

12.1 Handling precautions

- 1) The polarizing plate may break easily so be careful when handling it. Do not touch, press or rub it with a hard-material tool like tweezers.
- 2) Do not touch the polarizing plate surface with bare hands so as not to make it dirty. If the surface or other related part of the polarizing plate is dirty, soak a soft cotton cloth or chamois leather in benzine and wipe off with it. Do not use chemical liquids such as acetone, toluene and isopropyl alcohol. Failure to do so may bring chemical reaction phenomena and deteriorations.
- 3) Remove any spit or water immediately. If it is left for hours, the suffered part may deform or decolorize.
- 4) If the LCD element breaks and any LC stuff leaks, do not suck or lick it. Also if LC stuff is stuck on your skin or clothing, wash thoroughly with soap and water immediately.

12.2 Installing precautions

- 1) The PCB has many ICs that may be damaged easily by static electricity. To prevent

breaking by static electricity from the human body and clothing, earth the human body properly using the high resistance and discharge static electricity during the operation. In this case, however, the resistance value should be approx. $1M\Omega$ and the resistance should be placed near the human body rather than the ground surface. When the indoor space is dry, static electricity may occur easily so be careful. We recommend the indoor space should be kept with humidity of 60% or more. When a soldering iron or other similar tool is used for assembly, be sure to earth it.

- 2) When installing the module and ICs, do not bend or twist them. Failure to do so may crack LC element and cause circuit failure.
- 3) To protect LC element, especially polarizing plate, use a transparent protective plate (e.g., acrylic plate, glass etc) for the product case.
- 4) Do not use an adhesive like a both-side adhesive tape to make LCD surface (polarizing plate) and product case stick together. Failure to do so may cause the polarizing plate to peel off.

12.3 Storage precautions

- 1) Avoid a high temperature and humidity area. Keep the temperature between 0°C and 35°C and also the humidity under 60%.
- 2) Choose the dark spaces where the product is not exposed to direct sunlight or fluorescent light.
- 3) Store the products as they are put in the boxes provided from us or in the same conditions as we recommend.

12.4 Operating precautions

- 1) Do not boost the applied drive voltage abnormally. Failure to do so may break ICs. When applying power voltage, check the electrical features beforehand and be careful. Always turn off the power to the LC module controller before removing or inserting the LC module input connector. If the input connector is removed or inserted while the power is turned on, the LC module internal circuit may break.
- 2) The display response may be late if the operating temperature is under the normal standard, and the display may be out of order if it is above the normal standard. But this is not a failure; this will be restored if it is within the normal standard.
- 3) The LCD contrast varies depending on the visual angle, ambient temperature, power voltage etc. Obtain the optimum contrast by adjusting the LC drive voltage.
- 4) When carrying out the test, do not take the module out of the low-temperature space suddenly. Failure to do so will cause the module condensing, leading to malfunctions.
- 5) Make certain that each signal noise level is within the standard (L level: $0.2V_{dd}$ or

less and H level: 0.8Vdd or more) even if the module has functioned properly. If it is beyond the standard, the module may often malfunction. In addition, always connect the module when making noise level measurements.

- 6) The CMOS ICs are incorporated in the module and the pull-up and pull-down function is not adopted for the input so avoid putting the input signal open while the power is ON.
- 7) The characteristic of the semiconductor element changes when it is exposed to light emissions, therefore ICs on the LCD may malfunction if they receive light emissions. To prevent these malfunctions, design and assemble ICs so that they are shielded from light emissions.
- 8) Crosstalk occurs because of characteristics of the LCD. In general, crosstalk occurs when the regularized display is maintained. Also, crosstalk is affected by the LC drive voltage. Design the contents of the display, considering crosstalk.

12.5 Other

- 1) Do not disassemble or take the LC module into pieces. The LC modules once disassembled or taken into pieces are not the guarantee articles.
- 2) The residual image may exist if the same display pattern is shown for hours. This residual image, however, disappears when another display pattern is shown or the drive is interrupted and left for a while. But this is not a problem on reliability.
- 3) AMIPRE will provide one year warrantee for all products and three months warrantee for all repairing products.

13 OUTLINE DIMENSION

REV	REVISION RECORD	DATE	NAME
0	NEW RELEASE	03-19-09	SNOW
1	Rename TF480272-2L-0 to 480272H3-TW1	03-09-09	SNOW

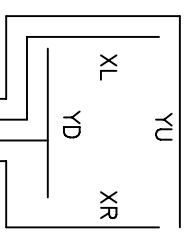
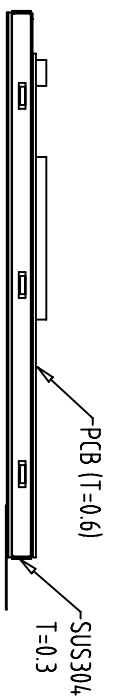

1	XR
2	YD
3	XL
4	YU

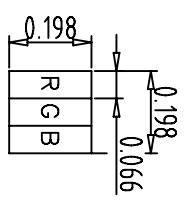

A Block

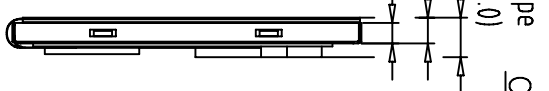
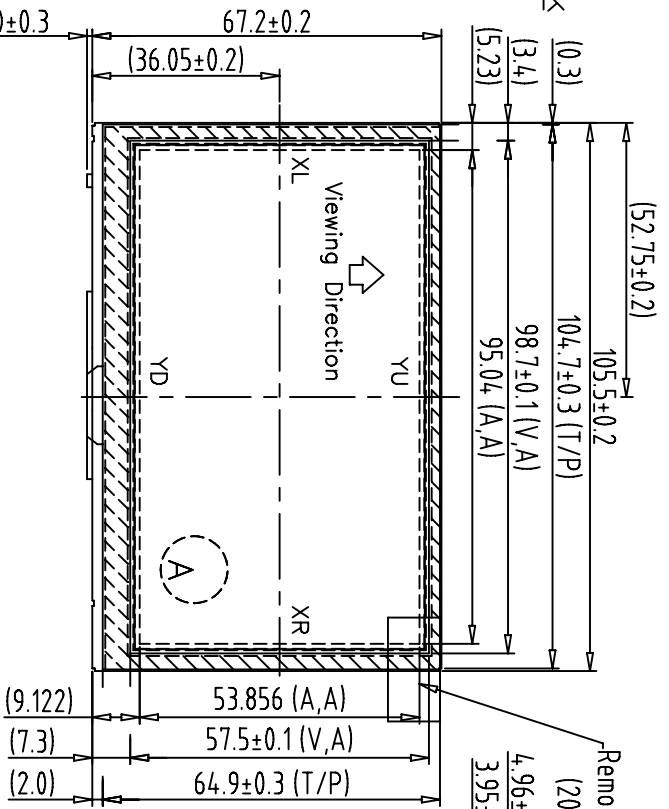

Remove tape
(20.0x10.0)

CIRCUIT DIAGRAM

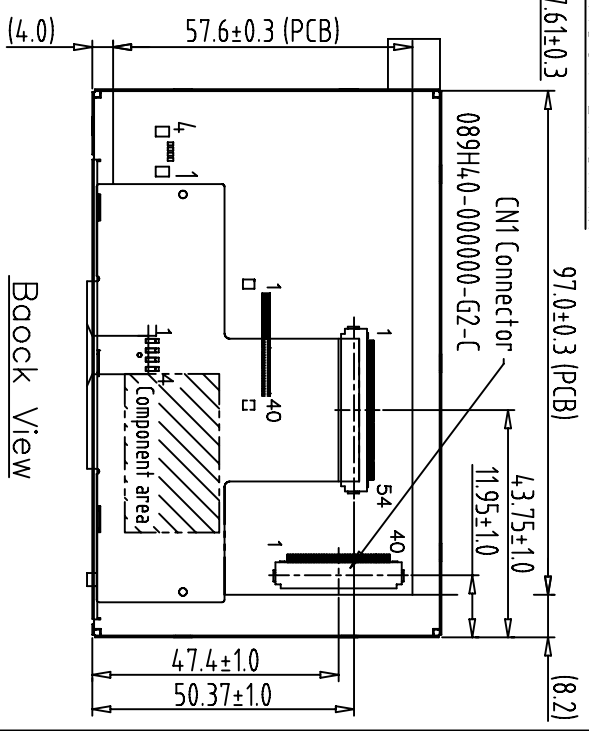

Back View

1	VSS	21	DB11
2	VSS	22	DB12
3	LED_A	23	DB13
4	LED_K	24	DB14
5	/RESET	25	DB15
6	RS	26	DB16
7	/CS	27	DB17
8	/MR	28	65K
9	/RD	29	VSS
10	DB0	30	SK
11	DB1	31	DO
12	DB2	32	DI
13	DB3	33	TPCS
14	DB4	34	IR0
15	DB5	35	VDD
16	DB6	36	VDD
17	DB7	37	VDD
18	DB8	38	VSS
19	DB9	39	VSS
20	DB10	40	VSS

Note:
1. Unless indicated, Tolerance ± 0.3 is adopted.
2. UV Glue For OLB Protection.
3. LCD 480x272 (R.G.B) TFT LCD => 480272H 4.3" TFT LCD

1	TF480272-24-0	7	TOLERANCE GRAD(E)	A	B	DIM.	MM	DRAW.	SNOW	DATE	TITLE
2		8	~6	0.05	0.1					03-19-09	480272H3-TW1
3		9	6~18	0.08	0.18	JE NO.		CHEK.		DATE	(4.3")
4		10	18~50	0.1	0.25						
5		11	50~180	0.2	0.4	PARTS NO. LCM	480272H3-TW1	APPD.		DATE	
6		12	180~	0.3	0.5						DWG. NO. *O90335MA
											SHEET 1 OF 1

AWM
OPTURE
晶采光電科技