



晶采光電科技股份有限公司
AMPIRE CO., LTD.

SPECIFICATIONS FOR LCD MODULE

CUSTOMER	
CUSTOMER PART NO.	
AMPIRE PART NO.	AM-640480ETMCW-00H(R)
APPROVED BY	
DATE	2009/08/03

- Approved For Specifications
 Approved For Specifications & Sample

AMPIRE CO., LTD.

**2F., No.88, Sec. 1, Sintai 5th Rd., Sijih City, Taipei County 221,
Taiwan (R.O.C.)台北縣汐止市新台五路一段 88 號 2 樓(東方科學園區 D 棟)
TEL:886-2-26967269 , FAX:886-2-26967196 or 26967270**

APPROVED BY	CHECKED BY	ORGANIZED BY

RECORD OF REVISION

Revision Date	Page	Contents	Editor
2005/07/15	-	New Release	Lee
2005/07/21	3	Backlight unit (One CCFL → Two CCFL)	Lee
2005/11/23	19-20	10. OUTLINE DIMENSION	Lee
2006/11/10	4	ABSOLUTE RATINGS ENVIRONMENT	Lee
2008/9/17	--	Correction the P/N to AM-640480ETMCW-00H(R)	Edward
	--	New logo and revise the address of company	Edward
	18	Add guarantee declaration	Edward
2009/1/8	19-20	Update Outline Dimension	Edward
2009/8/3	3	Correction the value of outline dimension	Edward

1. Introduction

Ampire Display Module AM640480E1TMCW00 is a color active matrix TFT-LCD that uses amorphous silicon TFT as a switching device . This model is composed of a TFT-LCD panel , a driving circuit and a backlight system . This TFT-LCD has a 10.4-inch diagonally measured active display area with VGA resolution(640(R.G.B) X 480) and can display up to 262,144 colors .

1-1. Features

- Wide viewing angle.
- High contrast ratio
- High operating temperature
- High color saturation

1-2. Applications

- Panel PC
- HMI (Human machine interface)
- Industrial application
- POS

2. Physical specifications

Item	Specifications	unit
Display resolution(dot)	640 x RGB (W) x 480(H)	dots
Active area	211.2 (W) x 158.4 (H)	mm
Screen size	10.4(Diagonal)	inch
Pixel pitch	0.33 (W) x 0.33 (H)	mm
Color configuration	R.G.B Vertical stripe	
Overall dimension	225.5±0.5(W)x176.3±0.5(H)x9.5±0.5(D)	mm
Weight	440(typ)	g
Surface treatment	Antiglare , Hard-Coating(3H)	
Backlight unit	Two CCFL	
Input signal	TTL	
Display color	262,144	colors

3. ABSOLUTE MAXIMUM RATINGS

3-1. ABSOLUTE RATINGS ENVIRONMENT

ITEM	CONDITIONS	NOTE
HIGH TEMPERATURE OPERATION	70°C , 240Hrs	(1)(2)
HIGH TEMPERATURE AND HIGH HUMIDITY OPERATION	60°C , 90%RH , 240Hrs	
HIGH TEMPERATURE STORAGE	80°C , 240Hrs	
LOW TEMPERATURE OPERATION	-20°C , 240Hrs	
LOW TEMPERATURE STORAGE	-20°C , 240Hrs	
THERMAL SHOCK (Non-operation)	-20°C (0.5Hr) ~80°C (0.5Hr) 100Cycle ; 1hour/cycle	
SHOCK (Non-Operation)	220G , 2ms , half sine wave 1 time for $\pm X$, $\pm Y$, $\pm Z$,	(2)(3)
VIBRATION (Non-Operation)	1.5G , 10~300Hz , 10min/cycle , 3 cycle each X,Y,Z	(2)(3)
ESD (Operation)	150Pf , 330Ω , 1sec/cycle 1) $\pm 8kV$: panel contact 2) $\pm 15kV$: panel non-contact	(2)

NOTE :

(1) Temperature and relative humidity range is shown in the figure below

(a) 90% RH Max.($T_a \leq 40^\circ C$)

(b) Wet-bulb temperature should be 39°C Max ($T_a > 40^\circ C$)

(c) No condensation

(2) No display malfunctions

(3) At testing Vibration and Shock , the fixture in holding the module has to be hard and rigid enough so that the module would not be twisted or bent by the fixture

(4) The temperature of panel display surface area should be 80°C Max

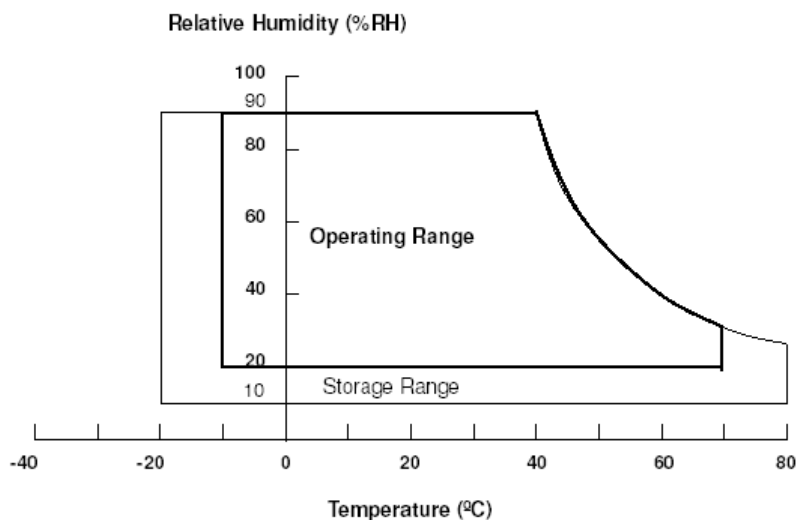

3-2. ELECTRICAL ABSOLUTE RATINGS

3-2-1 TFT LCD MODULE

Item	Symbol	Value		Unit	Remark
		Min.	Max.		
Power supply voltage	V_{CC}	-0.3	6.0	V	(1)
Logic input voltage	V_{IN}	-0.3	$V_{CC}+0.3$	V	

3-2-2 BACKLIGHT UNIT

Item	Symbol	Value		Unit	Remark
		Min.	Max.		
Lamp voltage	V_L	-	(2.5K)	V_{RMS}	(1)(2) $I_L = 5.5mA$
Lamp current	I_L	-	6	mA_{RMS}	(1)(2)
Lamp frequency	F_L	-	80	KHZ	

NOTE :

- (1) Permanent damage to the device may occur if maximum values are exceeded . Function operation should be restricted to the conditions described under Normal operating conditions .
- (2) Specified values are for lamp (Refer to 3.2 for further I_L information)

4. Electrical Characteristics

4.1 TFT LCD MODULE

Ta = 25 ± 2°C

Item	Symbol	Min.	Typ.	Max.	Unit	Remark	
Power supply voltage	V _{CC}	(3.0)	3.3	(3.6)	V		
Logic input voltage	V _{IH}	0.7 V _{CC}	-	V _{CC}	V		
	V _{IL}	0	-	0.3 V _{CC}	V		
Rush current	I _{RUSH}	-	-	(1)	A	(2)	
Power supply current	White	I _{DD 1}	-	(495)	-	mA	(3)a
	Black	I _{DD 2}	-	(450)	-	mA	(3)b
	Vertical stripe	I _{DD 3}	-	(563)	-	mA	(3)c

NOTE :

(1) The module should be always operated within above ranges

(2) Measurement condition

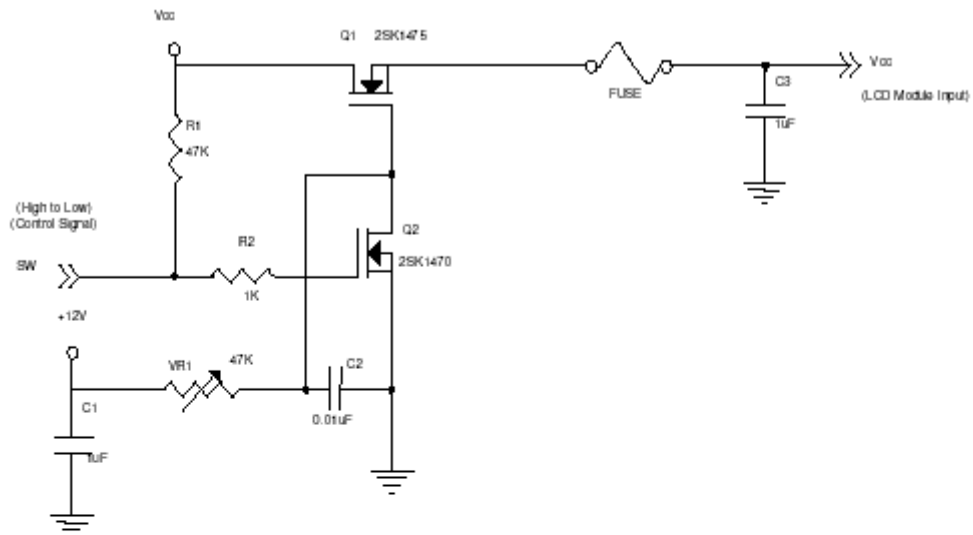

Vcc rising time is 470μs

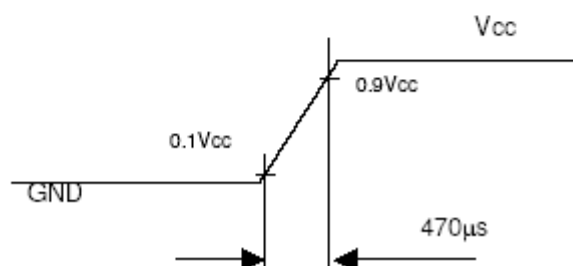

(3) The specified power supply current is under the conditions at $V_{CC} = 3.3V$, $T_a = 25 \pm 2 \text{ }^\circ\text{C}$, $f_v = 60\text{Hz}$, whereas a power dissipation check pattern below is displayed.

a. White Pattern



Active Area

b. Black Pattern

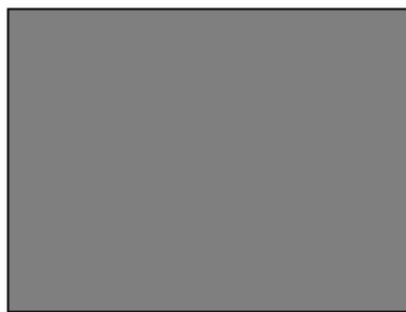

Active Area

c. Vertical Stripe Pattern

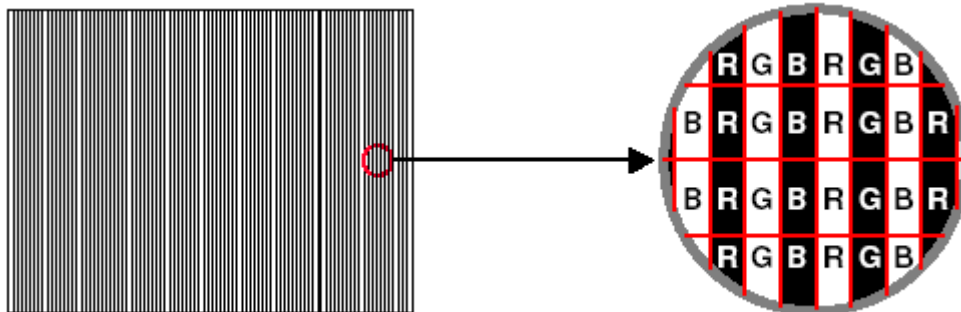

Active Area

4-2 BACKLIGHT UNIT

Item	Symbol	Value			Unit	Remark
		Min.	Min.	Max.		
Lamp input voltage	V_L	(440)	(490)	(540)	Vrms	(1), $I_L=(5.5)\text{mA}$
Lamp current	I_L	(2.0)	(5.5)	(6.0)	mArms	(1)
Lamp Turn on voltage	V_S	-	-	(770)	Vrms	(2) 25°C
		-	-	(960)	Vrms	(2) 0°C
Operating Frequency	F_L	(40)	-	(80)	KHz	(3)
Lamp Life Time	L_{BL}	(50K)	-	-	Hrs	(5)
Power Consumption	P_L	-	(5.39)	-	W	(4), $I_L=(5.5)\text{mA}$

Note :

- (1) I_L means the lamp current of one lamp.
- (2) The voltage shown above should be applied to the lamp for more than 1 second after startup . Otherwise the lamp may not be turned on .
- (3) The lamp frequency may produce interference with horizontal synchronous frequency from the display , and this may cause line flow on the display . In order to avoid interference , the lamp frequency should be detached from the horizontal synchronous frequency and its harmonics as far as possible.
- (4) $P_L = I_L \times V_L \times 2$
- (5) The lifetime of lamp can be defined as the time in which it continues to operate under the condition $T_a = 25 \pm 2^\circ\text{C}$ and $I_L = (5.5)\text{mArms}$ until one of the following events occurs.
 - (a) When the brightness becomes or lower than 50% of its original value.
 - (b) When the effective ignition length becomes or lower than 80% of its original value.(Effective ignition length is defined as an area that has less than 70% brightness compared to the brightness in the center point.)

5. BLOCK DIAGRAM

5-1 TFT LCD MODULE

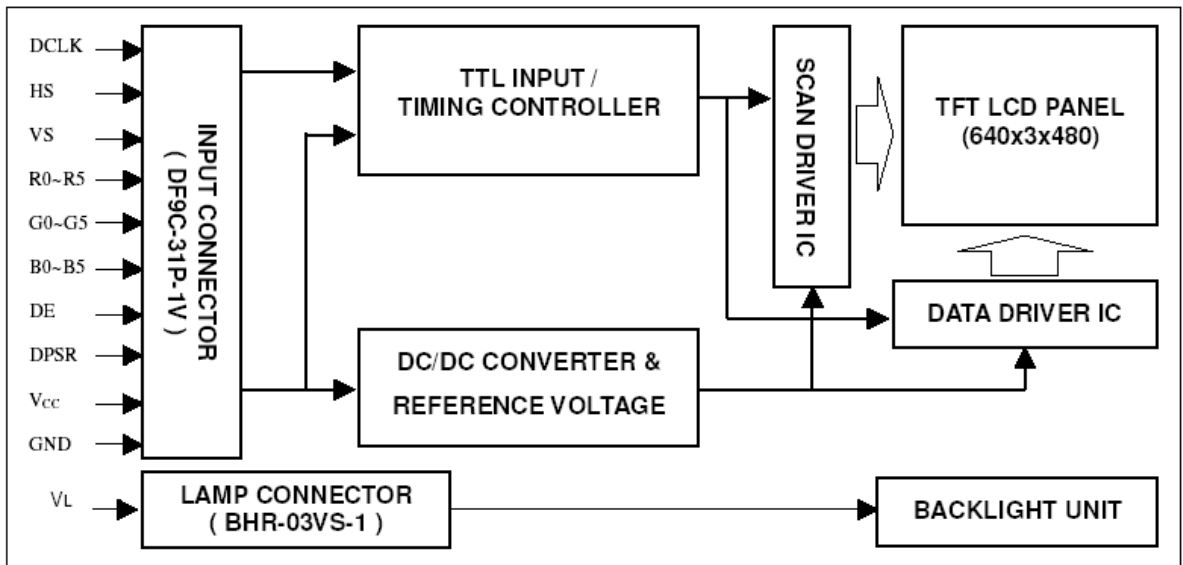

5-2 BACKLIGHT UNIT

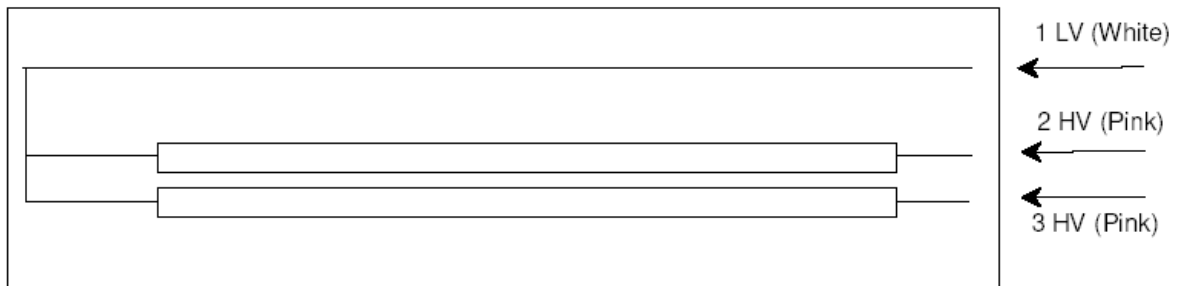

6. INPUT TERMINAL PIN ASSIGNMENT

6-1 TFT LCD MODULE

Pin no	Symbol	Function
1	GND	Ground
2	DCLK	Dot clock
3	HS	Horizontal synchronous
4	VS	Vertical synchronous
5	GND	Ground
6	R0	Red data (LSB)
7	R1	Red data
8	R2	Red data
9	R3	Red data
10	R4	Red data
11	R5	Red data (MSB)
12	GND	Ground
13	G0	Green data (LSB)
14	G1	Green data
15	G2	Green data
16	G3	Green data
17	G4	Green data
18	G5	Green data (MSB)
19	GND	Ground
20	B0	Blue data (LSB)
21	B1	Blue data
22	B2	Blue data
23	B3	Blue data
24	B4	Blue data
25	B5	Blue data (MSB)
26	GND	Ground
27	DE	Data enable signal
28	Vcc	Power supply
29	Vcc	Power supply
30	N.C.	Reserved , please keep it floating
31	DPSR	Selection of scan direction

Note : Connector Part No. : DF 9C-31P-1V or equivalent.

6-2 SCANNING DIRECTION

The following figures are seen from a front view and the arrow shows the direction of scan.

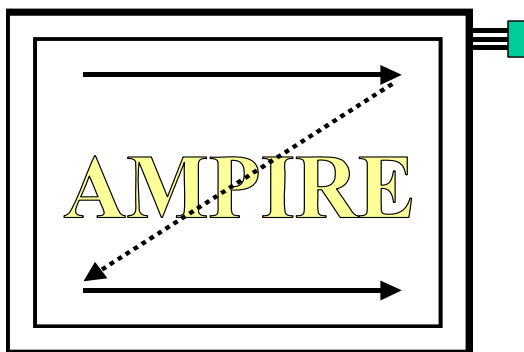

Figure1. Normal scan(DPSR : Low or Open)

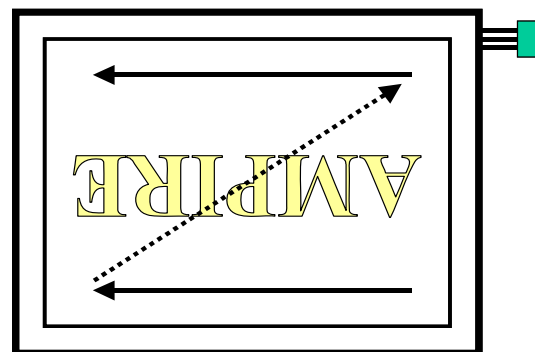

Figure2. Reverse scan(DPSR : High)

6-3 BACKLIGHT UNIT

Pin	Symbol	Description	Remark
1	GND	Ground	White
2	HV1	High voltage	Pink
3	HV2	High voltage	Pink

NOTE : Connector Part No : BHR-03VS-1 (J.S.T Mfg,Co,Ltd)

6-4 COLOR DATA INPUT ASSIGNMENT

The brightness of each primary color (red,green and blue) is based on the 6-bit gray scale data input for the color. The higher the binary input , the bright the color. The table below provides the assignment of color versus data input.

Color		Data Signal																	
		Red						Green						Blue					
		R5	R4	R3	R2	R1	R0	G5	G4	G3	G2	G1	G0	B5	B4	B3	B2	B1	B0
Basic Colors	Black	0	0	0	0	0	0	0	0	0	0	0	0	0	0	0	0	0	0
	Red	1	1	1	1	1	1	0	0	0	0	0	0	0	0	0	0	0	0
	Green	0	0	0	0	0	0	1	1	1	1	1	1	0	0	0	0	0	0
	Blue	0	0	0	0	0	0	0	0	0	0	0	0	1	1	1	1	1	1
	Cyan	0	0	0	0	0	0	1	1	1	1	1	1	1	1	1	1	1	1
	Magenta	1	1	1	1	1	1	0	0	0	0	0	0	1	1	1	1	1	1
	Yellow	1	1	1	1	1	1	1	1	1	1	1	1	0	0	0	0	0	0
	White	1	1	1	1	1	1	1	1	1	1	1	1	1	1	1	1	1	1
Gray Scale Of Red	Red(0) / Dark	0	0	0	0	0	0	0	0	0	0	0	0	0	0	0	0	0	0
	Red(1)	0	0	0	0	0	1	0	0	0	0	0	0	0	0	0	0	0	0
	Red(2)	0	0	0	0	1	0	0	0	0	0	0	0	0	0	0	0	0	0
	:	:	:	:	:	:	:	:	:	:	:	:	:	:	:	:	:	:	:
	:	:	:	:	:	:	:	:	:	:	:	:	:	:	:	:	:	:	:
	:	:	:	:	:	:	:	:	:	:	:	:	:	:	:	:	:	:	:
	Red(61)	1	1	1	1	0	1	0	0	0	0	0	0	0	0	0	0	0	0
	Red(62)	1	1	1	1	1	0	0	0	0	0	0	0	0	0	0	0	0	0
Red(63)	1	1	1	1	1	1	0	0	0	0	0	0	0	0	0	0	0	0	
Gray Scale Of Green	Green(0) / Dark	0	0	0	0	0	0	0	0	0	0	0	0	0	0	0	0	0	0
	Green(1)	0	0	0	0	0	0	0	0	0	0	0	1	0	0	0	0	0	0
	Green(2)	0	0	0	0	0	0	0	0	0	0	1	0	0	0	0	0	0	0
	:	:	:	:	:	:	:	:	:	:	:	:	:	:	:	:	:	:	:
	:	:	:	:	:	:	:	:	:	:	:	:	:	:	:	:	:	:	:
	:	:	:	:	:	:	:	:	:	:	:	:	:	:	:	:	:	:	:
	Green(61)	0	0	0	0	0	0	1	1	1	1	0	1	0	0	0	0	0	0
	Green(62)	0	0	0	0	0	0	1	1	1	1	1	0	0	0	0	0	0	0
Green(63)	0	0	0	0	0	0	1	1	1	1	1	1	0	0	0	0	0	0	
Gray Scale Of Blue	Blue(0) / Dark	0	0	0	0	0	0	0	0	0	0	0	0	0	0	0	0	0	0
	Blue(1)	0	0	0	0	0	0	0	0	0	0	0	0	0	0	0	0	0	1
	Blue(2)	0	0	0	0	0	0	0	0	0	0	0	0	0	0	0	0	1	0
	:	:	:	:	:	:	:	:	:	:	:	:	:	:	:	:	:	:	:
	:	:	:	:	:	:	:	:	:	:	:	:	:	:	:	:	:	:	:
	:	:	:	:	:	:	:	:	:	:	:	:	:	:	:	:	:	:	:
	Blue(61)	0	0	0	0	0	0	0	0	0	0	0	0	1	1	1	1	0	1
	Blue(62)	0	0	0	0	0	0	0	0	0	0	0	0	1	1	1	1	1	0
Blue(63)	0	0	0	0	0	0	0	0	0	0	0	0	1	1	1	1	1	1	

NOTE : 0 → Low Level Voltage , 1 → High Level Voltage

7. INPUT TIMING

7-1 INPUT SIGNAL TIMING SPECIFICATIONS

The input signal timing specifications are shown as the following table and timing diagram.

Signal	Item	Symbol	Min.	Typ.	Max.	Unit	Note
Dot Clock	Frequency	Fc	21	25.175	29	MHz	-
	Duty		0.4	0.5	0.6		-
Dot Data	Setup Time	Tlvs	(8)	-	-	ns	-
	Hold Time	Tlvh	(12)	-	-	ns	-
Vertical Active Display Term	Frame Rate	Fr	56	60	75	Hz	Tv=Tvd+Tvb
	Total	Tv	(690)	800	(1279)	Th	-
	Display	Tvd	640	640	640	Th	-
	Blank	Tvb	(50)	160	Tv-Tvd	Th	-
Horizontal Active Display Term	Total	Th	(482)	525	(959)	Tc	Th=Thd+Thb
	Display	Thd	480	480	480	Tc	-
	Blank	Thb	(2)	45	Th-Thd	Tc	-

INPUT SIGNAL TIMING DIAGRAM

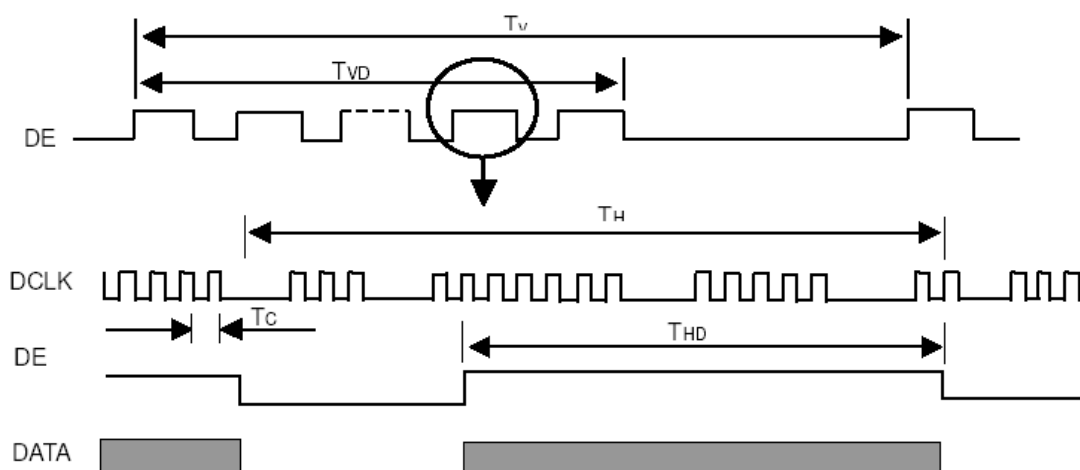

7-2 POWER ON/OFF SEQUENCE

To prevent a latch-up or DC operation of LCD module, the power on/off sequence should be as the diagram below.

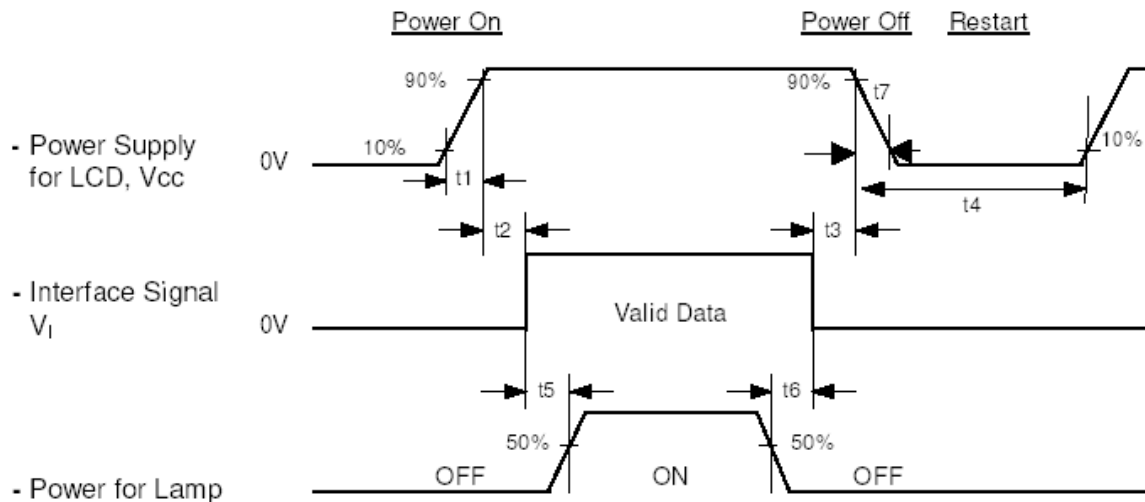

Timing Specifications :

$0.5 < t_1 \leq 10\text{ms}$
$0 < t_2 \leq 50\text{ms}$
$0 < t_3 \leq 50\text{ms}$
$t_4 \geq 500\text{ms}$
$t_5 \geq 200\text{ms}$
$t_6 \geq 200\text{ms}$

NOTE :

- (1) Please avoid floating state of interface signal at invalid period.
- (2) When the interface signal is invalid, be sure to pull down the power supply of LCD Vcc to 0V.
- (3) The Backlight inverter power must be turned on after the power supply for the logic and the interface signal is valid. The Backlight inverter power must be turned off before the power supply for the logic and the interface signal is invalid.

8. OPTICAL SPECIFICATIONS

8-1 TEST CONDITIONS

Item	Symbol	Value	Unit
Ambient Temperature	Ta	25±2	°C
Ambient Humidity	Ha	50±10	%RH
Supply Voltage	Vcc	(3.3)	V
Input Signal	According to typical value in "4. Electrical Characteristics"		
Lamp Current	I _L	(5.5)	mA _{RMS}
Inverter Frequency	F _L	(60)	KHz
Inverter	(Sumida IV40090T/B2)		

NOTE : I_L means the lamp current of one lamp.

8-2 OPTICAL SPECIFICATIONS

The relative measurement methods of optical characteristics are shown in 8-2.

The following items should be measured under the test conditions described in 8-1 and stable environment shown in Note (6)

Item		Symbol	Condition	Min.	Typ.	Max.	Unit	Remark
Response time	Rise	T _R	Θ _x =0° Θ _y =0°	-	(14)	(19)	ms	(1)
	Fall	T _F		-	(9)	(14)		
Contrast ratio		CR		(500)	(750)	-	-	(2)(6)
Viewing angle	Top	Θ _{y+}	CR ≥ 10	(80)	(85)	-	Deg.	(3)
	Bottom	Θ _{y-}		(80)	(85)	-		
	Left	Θ _{x-}		(80)	(85)	-		
	Right	Θ _{x+}		(80)	(85)	-		
Center Luminance of White		L _c		(320)	(380)	-	cd/m ²	(4)(6)
White Variation		δW		-	-	(1.4)	-	(5)
Color chromaticity	Red	R _x	Θ _x =0° Θ _y =0°	Typ - 0.03	(0.628)	Typ + 0.03		(3)(6)
		R _y			(0.347)			
	Green	G _x			(0.292)			
		G _y			(0.567)			
	Blue	B _x			(0.144)			
		B _y			(0.084)			
	White	W _x			0.313			
		W _y			0.329			

NOTE (1) Definition of Response Time (T_R , T_F) and measurement method :

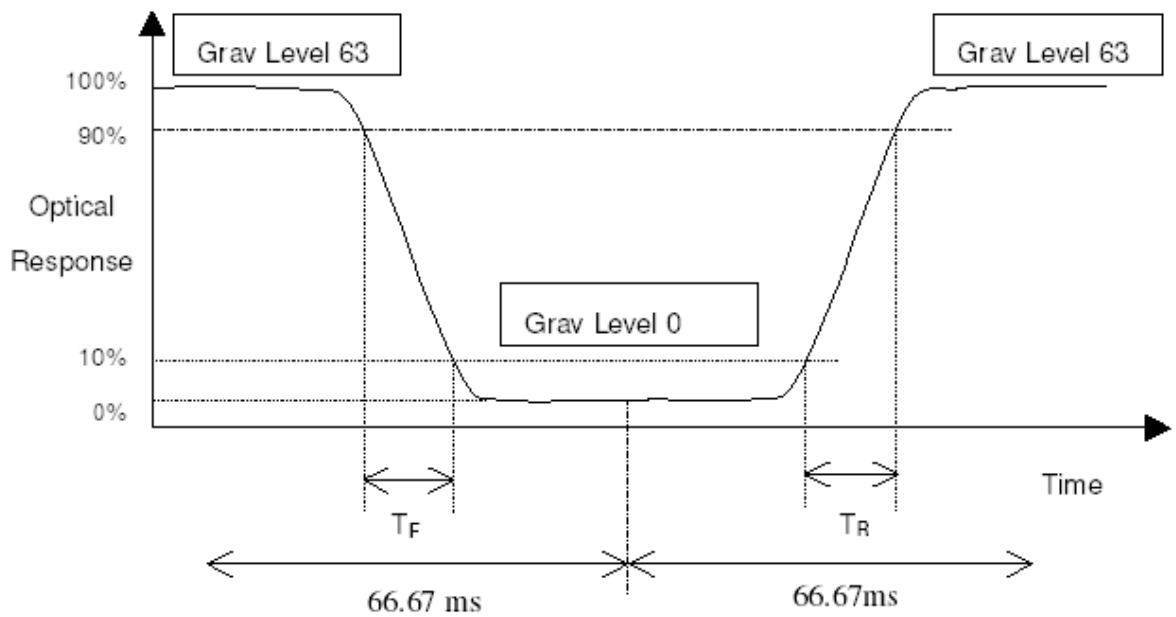

NOTE (2) Definition of Contrast Ratio (CR) :

The contrast ratio can be calculated by the following expression.

$$\text{Contrast Ratio (CR)} = L_{63} / L_0$$

L_{63} : Luminance of gray level 63

L_0 : Luminance of gray level 0

NOTE (3) Definition of Viewing Angle (θ_x , θ_y) :

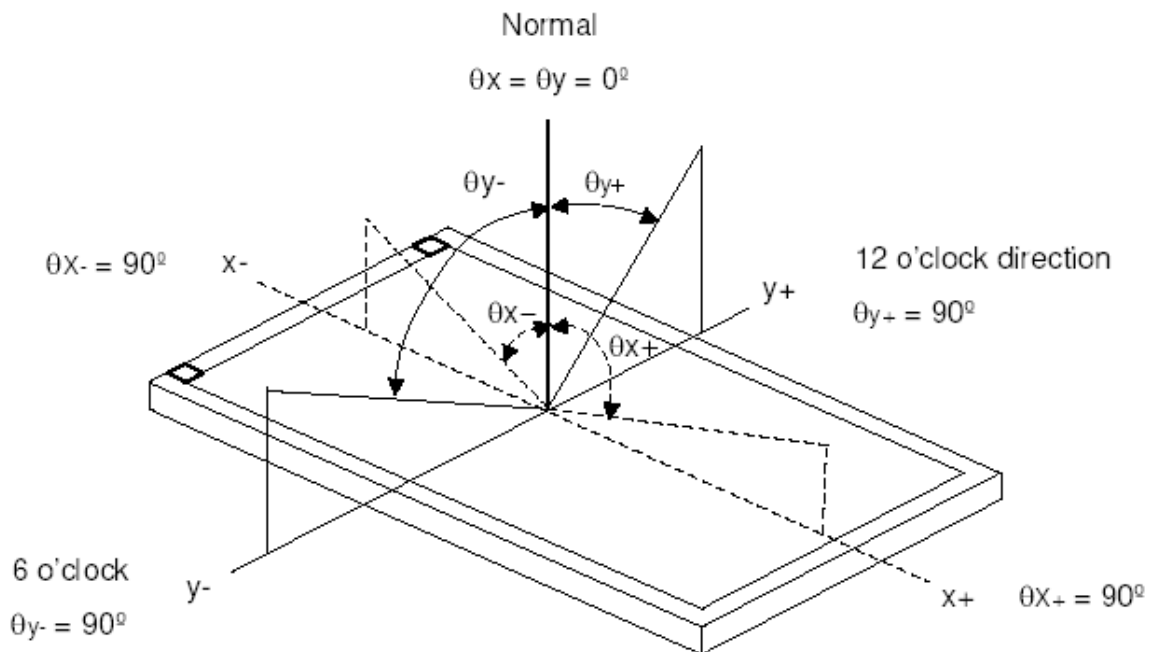

NOTE (4) Definition of Luminance of White(L_c) :

Measure the luminance of gray level 63 at center point

$L_c = L(5)$; $L(X)$ is corresponding to the luminance of the point X at Figure in Note(5)

NOTE (5) Definition of White Variation (δW) :

Measure the luminance of gray level 63 at center point

$\delta W = \text{Max}[L(1), L(2), L(3), L(4), L(5)] / \text{Min}[L(1), L(2), L(3), L(4), L(5)]$

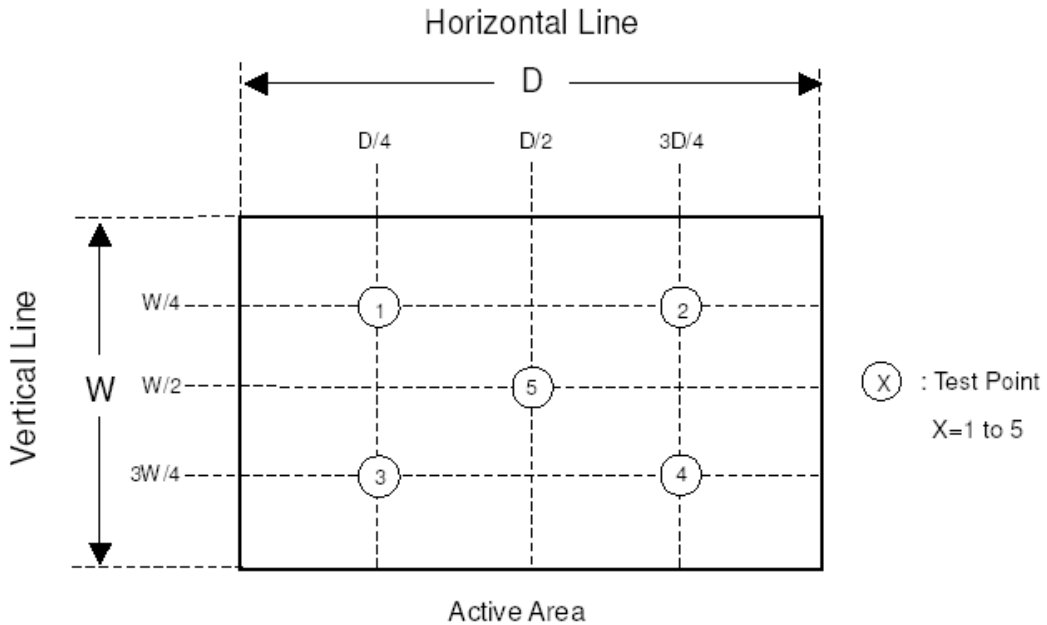

NOTE (6) Measurement Setup

The LCD module should be stabilized at given temperature for 20 minutes to avoid abrupt temperature change during measuring. In order to stabilize the luminance, the measurement should be executed after lighting Backlight for 20 minutes in a windless room.

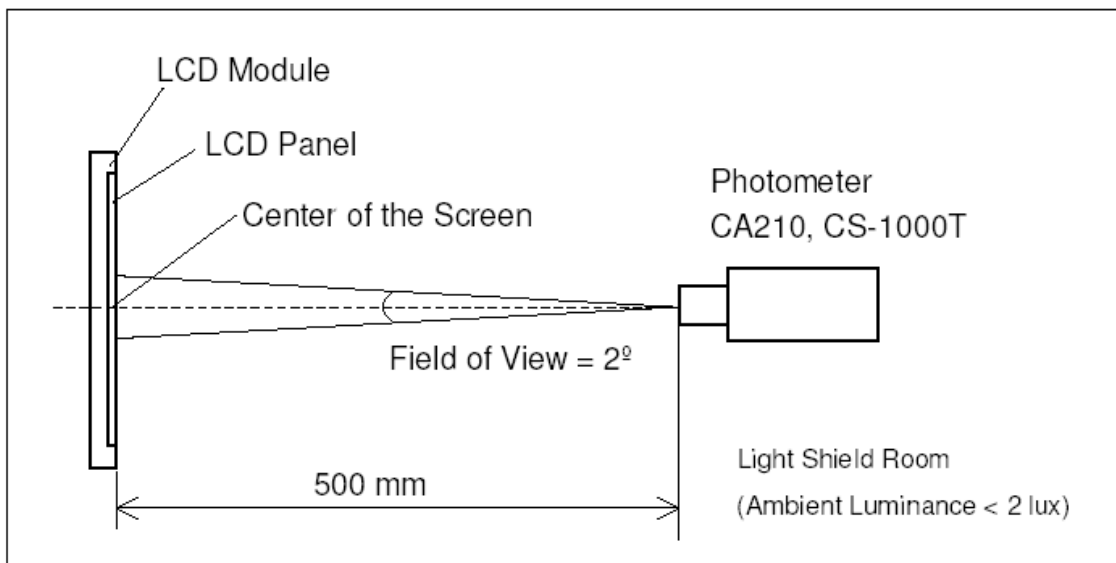

9. USE PRECAUTIONS

9-1 Handling precautions

- (1) The polarizing plate may break easily so be careful when handling it. Do not touch, press or rub it with a hard-material tool like tweezers.
- (2) Do not touch the polarizing plate surface with bare hands so as not to make it dirty. If the surface or other related part of the polarizing plate is dirty, soak a soft cotton cloth or chamois leather in benzene and wipe off with it. Do not use chemical liquids such as acetone, toluene and isopropyl alcohol. Failure to do so may bring chemical reaction phenomena and deteriorations.
- (3) Remove any spit or water immediately. If it is left for hours, the suffered part may deform or decolorize.
- (4) If the LCD element breaks and any LC stuff leaks, do not suck or lick it. Also if LC stuff is stuck on your skin or clothing, wash thoroughly with soap and water immediately.

9-2 Installing precautions

- (1) The PCB has many ICs that may be damaged easily by static electricity. To prevent breaking by static electricity from the human body and clothing, earth the human body properly using the high resistance and discharge static electricity during the operation. In this case, however, the resistance value should be approx. $1M\Omega$ and the resistance should be placed near the human body rather than the ground surface. When the indoor space is dry, static electricity may occur easily so be careful. We recommend the indoor space should be kept with humidity of 60% or more. When a soldering iron or other similar tool is used for assembly, be sure to earth it.
- (2) When installing the module and ICs, do not bend or twist them. Failure to do so may crack LC element and cause circuit failure.
- (3) To protect LC element, especially polarizing plate, use a transparent protective plate (e.g., acrylic plate, glass etc) for the product case.
- (4) Do not use an adhesive like a both-side adhesive tape to make LCD surface (polarizing plate) and product case stick together. Failure to do so may cause the polarizing plate to peel off

9-3 Storage precautions

- (1) Avoid a high temperature and humidity area. Keep the temperature between 0°C and 35°C and also the humidity under 60%.
- (2) Choose the dark spaces where the product is not exposed to direct sunlight or fluorescent light.
- (3) Store the products as they are put in the boxes provided from us or in the same conditions as we recommend.

9-4 Operating precautions

- (1) Do not boost the applied drive voltage abnormally. Failure to do so may break ICs. When applying power voltage, check the electrical features beforehand and be careful. Always turn off the power to the LC module controller before removing or inserting the LC module input connector. If the input connector is removed or inserted while the power is turned on, the LC module internal circuit may break.
- (2) The display response may be late if the operating temperature is under the normal standard, and the display may be out of order if it is above the normal standard. But this is not a failure; this will be restored if it is within the normal standard.
- (3) The LCD contrast varies depending on the visual angle, ambient temperature, power voltage etc. Obtain the optimum contrast by adjusting the LC drive voltage.
- (4) When carrying out the test, do not take the module out of the low-temperature space suddenly. Failure to do so will cause the module condensing, leading to malfunctions.
- (5) Make certain that each signal noise level is within the standard (L level: 0.2V_{dd} or less and H level: 0.8V_{dd} or more) even if the module has functioned properly. If it is beyond the standard, the module may often malfunction. In addition, always connect the module when making noise level measurements.
- (6) The CMOS ICs are incorporated in the module and the pull-up and pull-down function is not adopted for the input so avoid putting the input signal open while the power is ON.
- (7) The characteristic of the semiconductor element changes when it is exposed to light emissions, therefore ICs on the LCD may malfunction if they receive light emissions. To prevent these malfunctions, design and assemble ICs so that they are shielded from light emissions.
- (8) Crosstalk occurs because of characteristics of the LCD. In general, crosstalk occurs when the regularized display is maintained. Also, crosstalk is affected by the LC drive voltage. Design the contents of the display, considering crosstalk.

9-5 Other

- (1) Do not disassemble or take the LC module into pieces. The LC modules once disassembled or taken into pieces are not the guarantee articles.
- (2) The residual image may exist if the same display pattern is shown for hours. This residual image, however, disappears when another display pattern is shown or the drive is interrupted and left for a while. But this is not a problem on reliability.
- (3) AMIPRE will provide one year warranty for all products and three months warranty for all repairing products.

10. OUTLINE DIMENSION

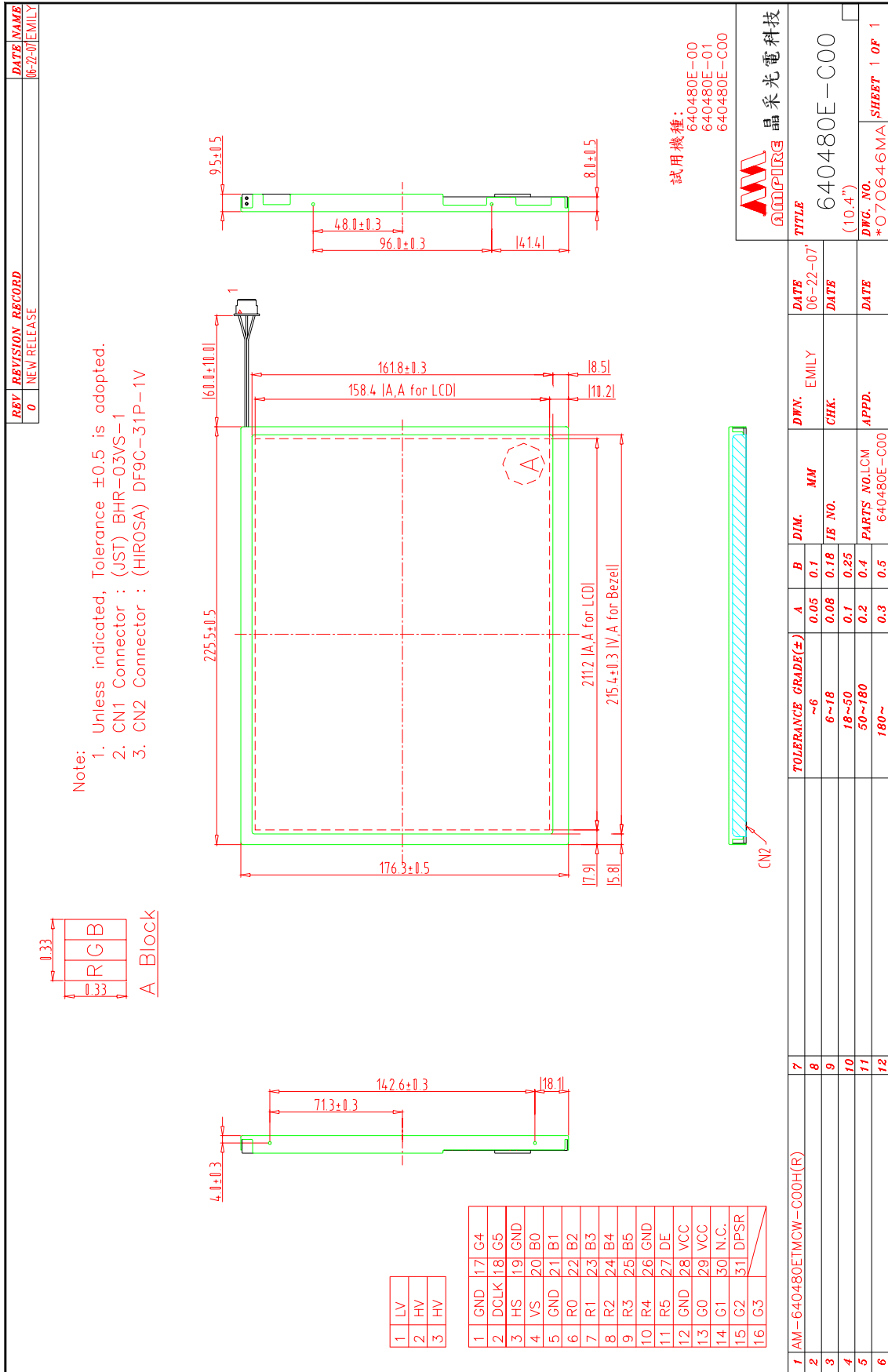

REV	REVISION RECORD	DATE NAME
0	NEW RELEASE	07-03-07 EMILY

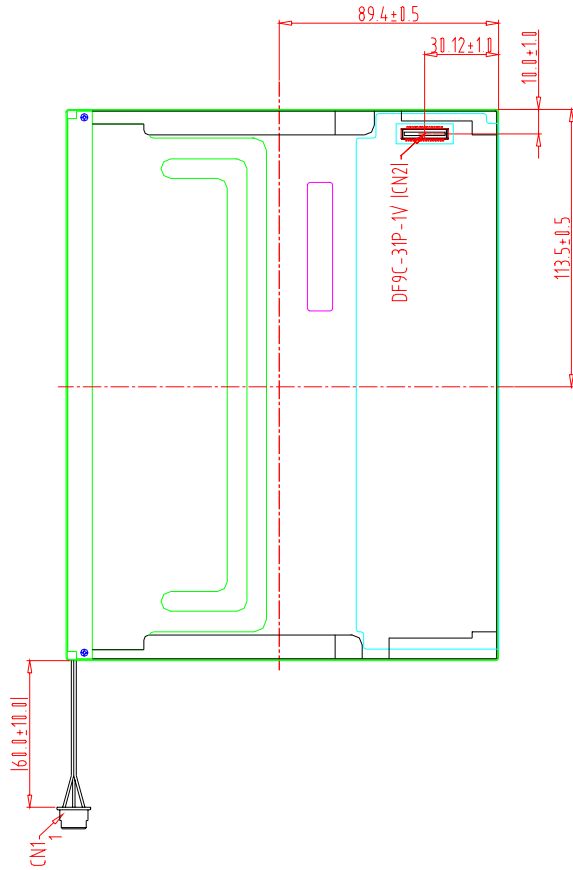

Back view

試用機種：
640480E-00
640480E-01
640480E-C00

晶采光電科技
AMPICORP

TITLE
640480E-C00
(10.4")

DWG. NO. *O7O7O1MA SHEET 1 OF 1

DATE	07-03-07	DFN.	EMILY
DATE		CHK.	
DATE		APPD.	
DIM.	MM	PARTS NO.	LCM-1
A	B	IB NO.	
0.05	0.1		
0.08	0.18		
0.1	0.25		
0.2	0.4		
0.3	0.5		
TOLERANCE GRADE(±)			
~6			
6~18			
18~50			
50~180			
180~			

- Note:
1. Unless indicated, Tolerance ± 0.5 is adopted.
 2. CN1 Connector : (JST) BHR-03VS-1
 3. CN2 Connector : (HIROSA) DF9C-31P-1V

1	LV
2	HV
3	HV

1	GND	17	G4
2	DCLK	18	G5
3	HS	19	GND
4	VS	20	B0
5	GND	21	B1
6	RO	22	B2
7	R1	23	B3
8	R2	24	B4
9	R3	25	B5
10	R4	26	GND
11	R5	27	DE
12	GND	28	VCC
13	G0	29	VCC
14	G1	30	N.C.
15	G2	31	DPSR
16	G3		