



晶采光電科技股份有限公司  
AMPIRE CO., LTD.

## SPECIFICATIONS FOR LCD MODULE

<b>CUSTOMER</b>	
<b>CUSTOMER PART NO.</b>	
<b>AMPIRE PART NO.</b>	<b>AM-640480G2TNQW-00H</b>
<b>APPROVED BY</b>	
<b>DATE</b>	

Approved For Specifications

Approved For Specifications & Sample

AMPIRE CO., LTD.

2F., No.88, Sec. 1, Sintai 5th Rd., Sijhih City, Taipei County 221, Taiwan (R.O.C.)

台北縣汐止市新台五路一段 88 號 2 樓(東方科學園區 D 棟)

TEL:886-2-26967269 , FAX:886-2-26967196 or 26967270

APPROVED BY	CHECKED BY	ORGANIZED BY

## RECORD OF REVISION

Revision Date	Page	Contents	Editor
2008/6/16	--	New Release	Sunglin
2008/9/8	3	Correct the physical specification	Sunglin
2009/3/17	7	Correct LED PWM Frequency	JOHN

## 1. INTRODUCTION

This is a color active matrix TFT-LCD that uses amorphous silicon TFT as a switching device . This model is composed of a 5.7inch TFT-LCD panel, touch panel, a driving circuit and LED backlight system . This TFT-LCD has a high resolution (640(R.G.B) X 480) and can display up to 262,144 colors .

### 1-1. Features

- VGA Resolution
- 6 Bits color driver with 1 channel TTL interface
- Wide range operation temperature

## 2. PHYSICAL SPECIFICATIONS

Item	Specifications	unit
Display resolution(dot)	640RGB (W) x 480(H)	dots
Display area	115.2 (W) x 86.4 (H)	mm
Pixel pitch	0.18 (W) x 0.18 (H)	mm
Color configuration	R.G.B Vertical stripe	
Overall dimension	127.0(W)x98.43(H)x6.6(D)---(Typ)	mm
Surface treatment	Antiglare , Hard-Coating(3H)	
Brightness	500	cd/m <sup>2</sup>
Contrast ratio	250 : 1	
Backlight unit	LED	
Display color	262,144	colors
Viewing Direction	12 o'clock	
Display Mode	Normally White	

### 3. ABSOLUTE MAXIMUM RATINGS

ITEM	SYMBOL	MIN	MAX	UNIT	NOTE
Power Supply Voltage	V <sub>cc</sub>	-0.5	5	V	
Signal Input Voltage	DCLK, DE R0~R5 G0~G5 B0~B5	-0.5	V <sub>cc</sub> + 0.5	V	
Operation Temperature	Top	-20	70	°C	(1)
Storage Temperature	Tstg	-30	80	°C	(1)

### 4. ELECTRICAL CHARACTERISTICS

#### 4-1 TFT LCD Module voltage

ITEM	SYMBOL	MIN	TYP	MAX	UNIT	NOTE
Power Voltage For LCD	V <sub>CC</sub>	3.0	3.3	3.6	V	(1)
Power Voltage For VLED	V <sub>DD</sub>	--	5.0	--	V	
Logic Input Voltage	V <sub>IH</sub>	V <sub>CC</sub> *0.7	--	V <sub>CC</sub>	V	
	V <sub>IL</sub>	0	--	V <sub>CC</sub> *0.3	V	
ADJ Input Voltage	V <sub>IH</sub>	3.0	--	5.0	V	
	V <sub>IL</sub>	GND	--	0.3	V	

2. LED Life Time : MTBF 20,000 hours.

#### 4-2 TFT LCD current consumption

ITEM	SYMBOL	MIN	TYP	MAX	UNIT	NOTE
LCD Power Current	I <sub>cc</sub>	-	82	-	mA	(1)
LED Power Current	I <sub>LED</sub> (V <sub>LED</sub> =5V)	-	290	-	mA	(2)

NOTE : (1) Typ : under 64 gray pattern    Max : under black pattern



(a) 64 Gray Pattern



(b) Black Pattern

(2) Typ : When V<sub>LED</sub> is 5.0V    Max : When V<sub>LED</sub> is 4.5V

One LED Dice :

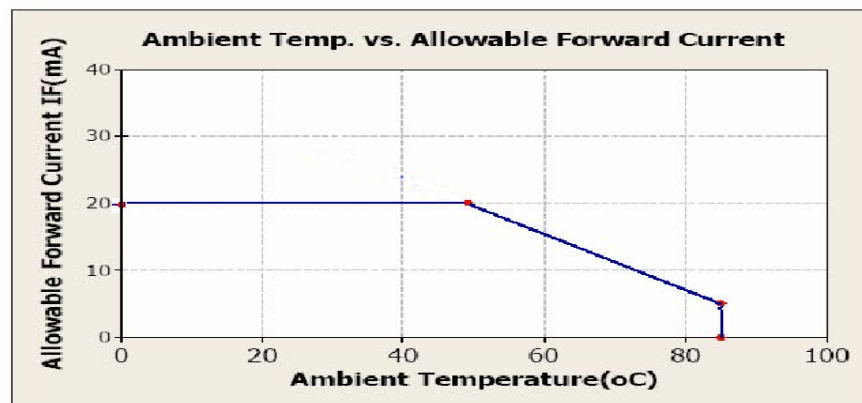

## 6. INTERFACE

Pin No	Symbol	Function
1	U/D	Up or Down Display Control
2	(NC)	No connection
3	Hsync(NC)	Horizontal SYNC. (Sync mode used)
4	VLED	Power Supply for LED
5	VLED	Power Supply for LED
6	VLED	Power Supply for LED
7	Vcc	Power Supply for LCD
8	Vsync(NC)	Vertical SYNC. (Sync mode used)
9	DE	Data Enable
10	Vss	Power Ground
11	Vss	Power Ground
12	ADJ	Adjust for LED Brightness
13	B5	Blue Data 5 (MSB)
14	B4	Blue Data 4
15	B3	Blue Data 3
16	Vss	Power Ground
17	B2	Blue Data 2
18	B1	Blue Data 1
19	B0	Blue Data 0 (LSB)
20	Vss	Power Ground
21	G5	Green Data 5 (MSB)
22	G4	Green Data 4
23	G3	Green Data 3
24	Vss	Power Ground
25	G2	Green Data 2
26	G1	Green Data 1
27	G0	Green Data 0 (LSB)
28	Vss	Power Ground
29	R5	Red Data 5 (MSB)
30	R4	Red Data 4
31	R3	Red Data 3
32	Vss	Power Ground
33	R2	Red Data 2
34	R1	Red Data 1
35	R0	Red Data 0 (LSB)
36	Vss	Power Ground
37	Vss	Power Ground
38	DCLK	Clock Signals
39	Vss	Power Ground
40	L/R	Left or Right Display Control

NOTE :

1. ADJ adjust brightness to control Pin , Pulse duty the bigger the brighter.

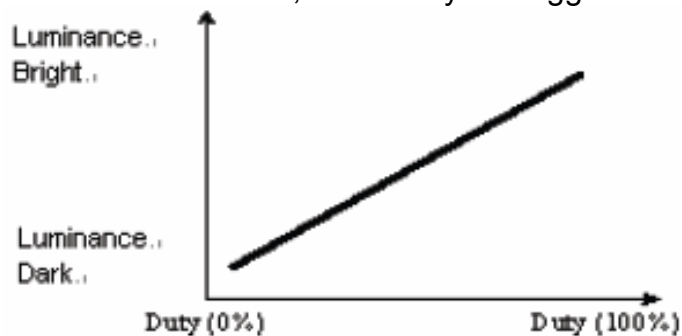

2. ADJ signal = 0 ~ 5.0V , operation frequency : 300Hz~1KHz

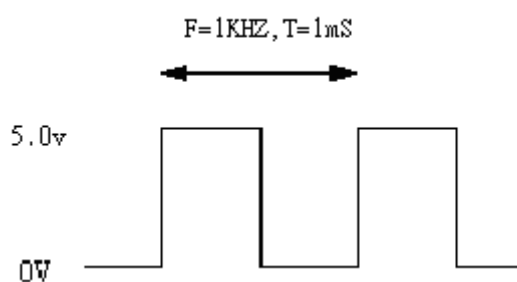

3. VSS Pin must ground contact , can not be floating.

4. U/D and L/R are controlled function

L/R	U/D	Function
1	0	Normally display
0	0	Left and Right opposite
1	1	Up and Down opposite
0	1	Left and Right opposite , Up and Down opposite

## 7. INPUT SIGNAL :

### 7-1 Timing Specification.

PARAMETER	Symbol	Min.	Typ.	Max	Unit
CLK frequency	F <sub>CPH</sub>		25.175		MHz
CLK period	T <sub>CPH</sub>	-	39.7	-	ns
CLK pulse duty	T <sub>CWH</sub>	40	50	60	%
HS period	T <sub>H</sub>	-	800	-	T <sub>CPH</sub>
HS pulse width	T <sub>WH</sub>	5	30	-	T <sub>CPH</sub>
HS-first horizontal data time	T <sub>HS</sub>	112	144	175	T <sub>CPH</sub>
DEN pulse width	T <sub>EP</sub>	-	640	-	T <sub>CPH</sub>
VS pulse width	T <sub>WV</sub>	1	3	5	T <sub>H</sub>
VS-DEN time	T <sub>STV</sub>	-	35	-	T <sub>H</sub>
VS period	T <sub>V</sub>	-	525	-	T <sub>H</sub>

**Note:** When SYNC mode is used, 1st data start from 144th CLK after HS falling (when STHD[5:0]=00000)

PARAMETER	Symbol	Min.	Typ.	Max	Unit
OEV pulse width	T <sub>OEV</sub>		100	-	T <sub>CPH</sub>
CKV pulse width	T <sub>CKV</sub>	-	96	-	T <sub>CPH</sub>
HS-CKV time	T <sub>1</sub>	-	52	-	T <sub>CPH</sub>
HS-OEV time	T <sub>2</sub>	-	8	-	T <sub>CPH</sub>
HS-POL time	T <sub>3</sub>	-	72	-	T <sub>CPH</sub>
STV setup time	T <sub>SUV</sub>	-	46	-	T <sub>CPH</sub>
STV pulse width	T <sub>WSTV</sub>	-	1	-	T <sub>H</sub>

## 7-2 Timing chart

### Clock and Data input waveforms

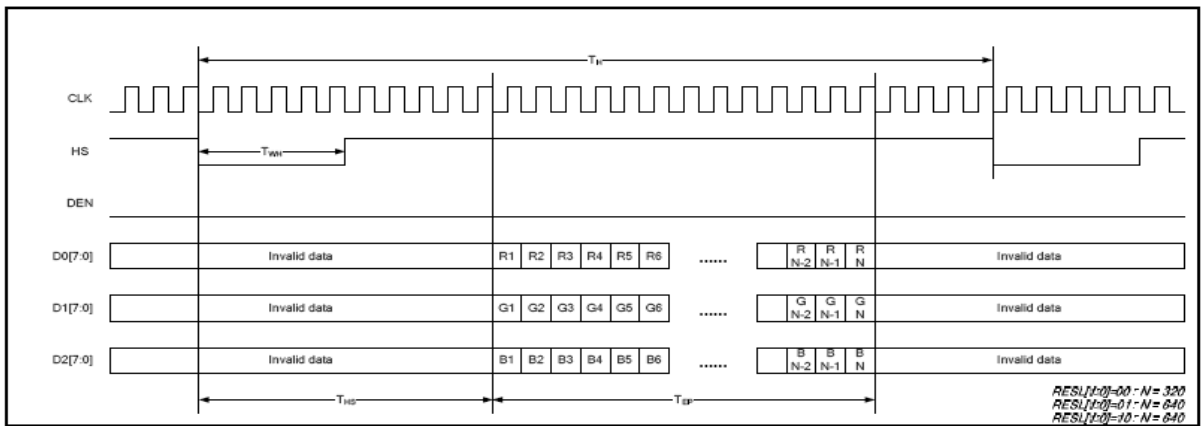
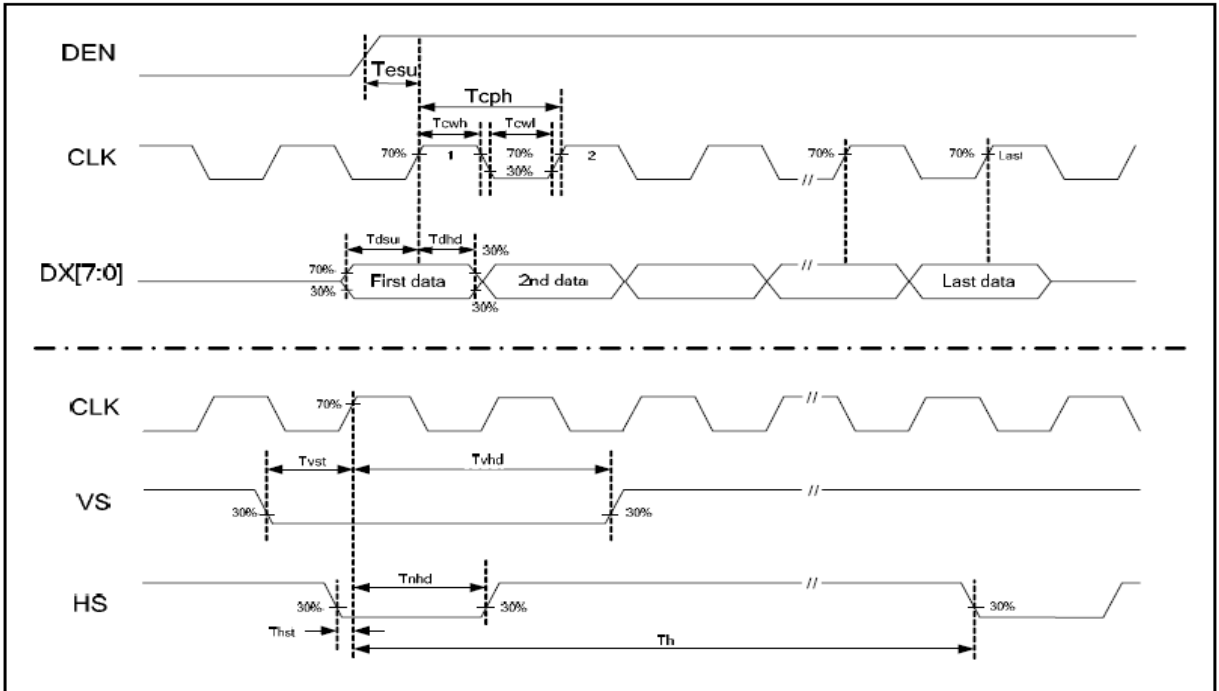

Parallel RGB SYNC Mode Horizontal Data Format

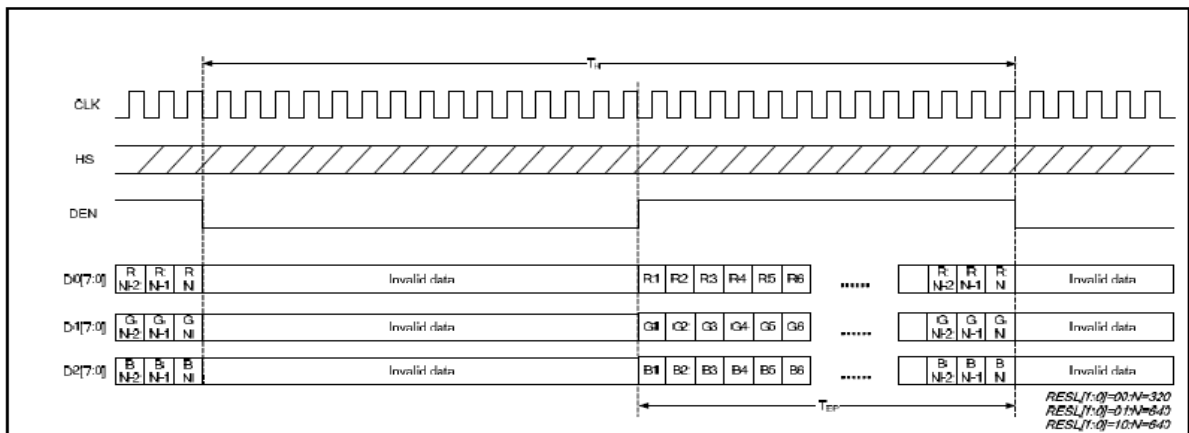

Parallel RGB DE Mode Horizontal Data Format

### 7-3 Color Data Assignment

COLOR	Input Data	R DATA					G DATA					B DATA							
		R5 MSB	R4	R3	R2	R1	R0 LSB	G5 MSB	G4	G3	G2	G1	G0 LSB	B5 MSB	B4	B3	B2	B1	B0 LSB
BASIC COLOR	BLACK	0	0	0	0	0	0	0	0	0	0	0	0	0	0	0	0	0	0
	RED(63)	1	1	1	1	1	1	0	0	0	0	0	0	0	0	0	0	0	0
	GREEN(63)	0	0	0	0	0	0	1	1	1	1	1	1	0	0	0	0	0	0
	BLUE(63)	0	0	0	0	0	0	0	0	0	0	0	0	1	1	1	1	1	1
	CYAN	0	0	0	0	0	0	1	1	1	1	1	1	1	1	1	1	1	1
	MAGENTA	1	1	1	1	1	1	0	0	0	0	0	0	1	1	1	1	1	1
	YELLOW	1	1	1	1	1	1	1	1	1	1	1	1	0	0	0	0	0	0
	WHITE	1	1	1	1	1	1	1	1	1	1	1	1	1	1	1	1	1	1
RED	RED(0)	0	0	0	0	0	0	0	0	0	0	0	0	0	0	0	0	0	0
	RED(1)	0	0	0	0	0	1	0	0	0	0	0	0	0	0	0	0	0	0
	RED(2)	0	0	0	0	1	0	0	0	0	0	0	0	0	0	0	0	0	0
	RED(62)	1	1	1	1	1	0	0	0	0	0	0	0	0	0	0	0	0	0
	RED(63)	1	1	1	1	1	1	0	0	0	0	0	0	0	0	0	0	0	0
GREEN	GREEN (0)	0	0	0	0	0	0	0	0	0	0	0	0	0	0	0	0	0	0
	GREEN (1)	0	0	0	0	0	0	0	0	0	0	0	1	0	0	0	0	0	0
	GREEN (2)	0	0	0	0	0	0	0	0	0	0	1	0	0	0	0	0	0	0
	GREEN (62)	0	0	0	0	0	0	1	1	1	1	1	0	0	0	0	0	0	0
	GREEN (63)	0	0	0	0	0	0	1	1	1	1	1	1	0	0	0	0	0	0
BLUE	BLUE (0)	0	0	0	0	0	0	0	0	0	0	0	0	0	0	0	0	0	0
	BLUE (1)	0	0	0	0	0	0	0	0	0	0	0	0	0	0	0	0	0	1
	BLUE (2)	0	0	0	0	0	0	0	0	0	0	0	0	0	0	0	0	1	0
	BLUE (62)	0	0	0	0	0	0	0	0	0	0	0	0	0	0	0	0	0	1
	BLUE (63)	0	0	0	0	0	0	0	0	0	0	0	0	0	0	0	0	1	0

NOTE : (1) Definition of Gray Scale , Color(n) : n is series of Gray Scale  
The more n value is the bright Gray Scale  
(2) Data : 1-High , 0-Low

## 8. OPTICAL CHARACTERISTICS

Item	Symbol	Condition	Min.	Typ.	Max.	Unit	Note	
Contrast ratio	CR	Point - 5 $\Theta = \Phi = 0^\circ$	200	250	--	--	(1)(2)(3)	
Luminance	Lw		--	500	-	cd/m <sup>2</sup>	(1)(3)	
Luminance Uniformity	$\Delta L$		70	75	-	%	(1)(3)	
Response Time ( White – Black )	$T_r + T_f$		--	50	--	ms	(1)(3)(5)	
Viewing Angle	Vertical	$\Theta$	$CR \geq 10$ Point - 5	80	100	-	Deg.	(1)(2)(4)
	Horizontal	$\Phi$		120	140	-		
Color chromaticity	Red	Rx	Point - 5 $\Theta = \Phi = 0^\circ$	0.566	0.616	0.666	--	(1)(3)
		Ry		0.302	0.352	0.402		
	Green	Gx		0.308	0.358	0.408		
		Gy		0.518	0.568	0.618		
	Blue	Bx		0.096	0.146	0.196		
		By		0.086	0.136	0.186		
	White	Wx		0.296	0.346	0.396		
		Wy		0.328	0.378	0.428		

NOTE :

- (1) Measure conditions :  $25^\circ\text{C} \pm 2^\circ\text{C}$  ,  $60 \pm 10\% \text{RH}$  under 10Lux , in the dark room by BM-7TOPCON) ,viewing  $2^\circ$  ,  $VCC=3.3\text{V}$  ,  $VDD=3.3\text{V}$

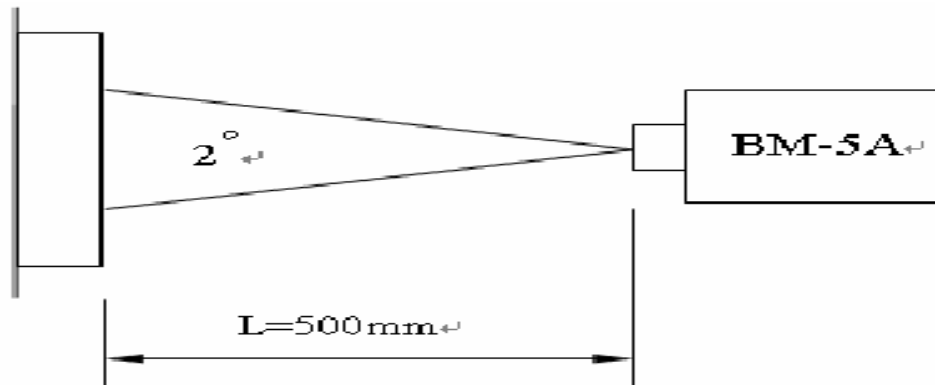

- (2) Definition of Contrast Ratio :

$$\text{Contrast Ratio (CR)} = (\text{White}) \text{ Luminance of ON} \div (\text{Black}) \text{ Luminance of OFF}$$

- (3) Definition of Luminance :

Definition of Luminance Uniformity

Measure white luminance on the point 5 as figure9-1

Measure white luminance on the point 1 ~ 9 as figure9-1

$$\Delta L = [ L(\text{MIN}) / L(\text{MAX}) ] \times 100\%$$

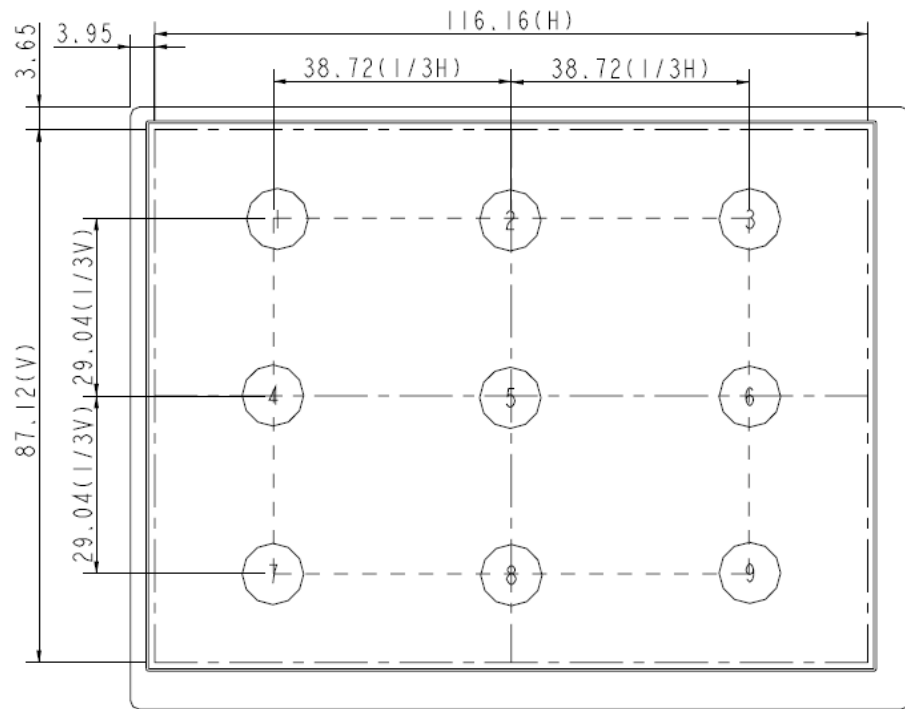

Fig9-1 Measuring point

(4) Definition of Viewing Angle( $\Theta, \Phi$ ), refer to Fig9-2 as below :

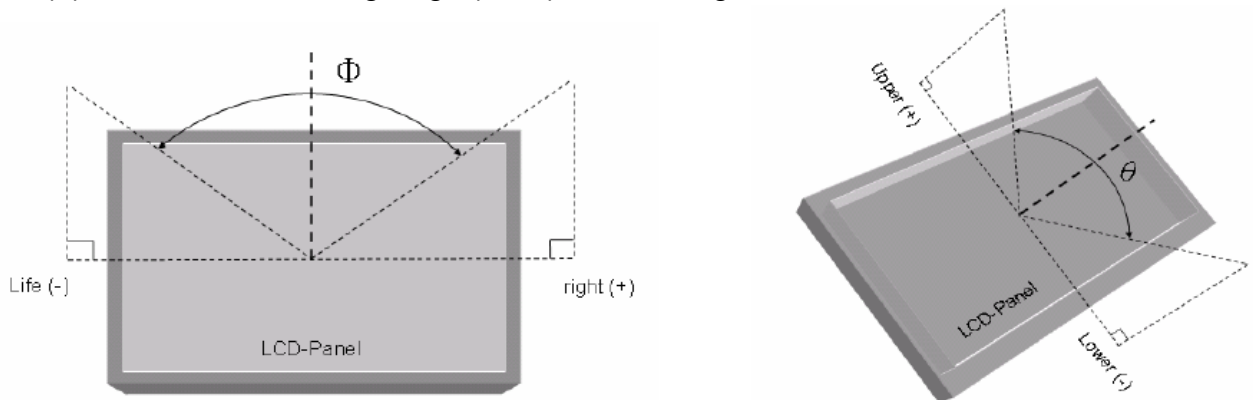

Fig9-2 Definition of Viewing Angle

(5) Definition of Response Time.(White – Black)

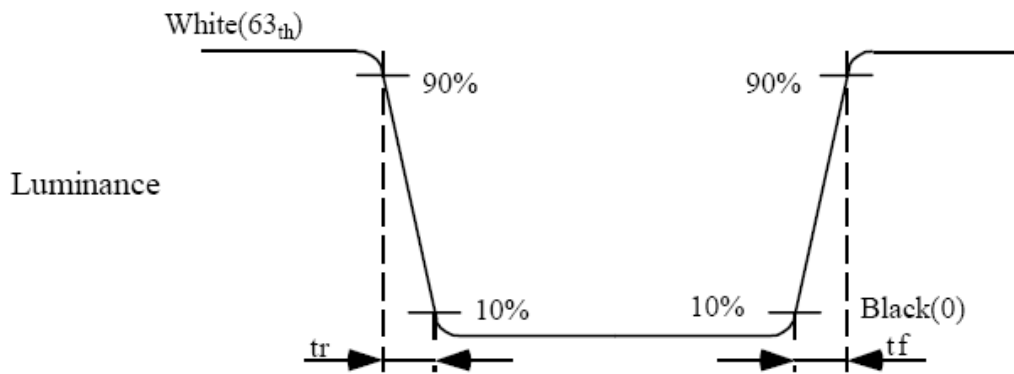

Fig9-3 Definition of Response Time(White-Black)

9 INCOMING INSPECTION STANDARD FOR TFT-LCD PANEL

DEFECT TYPE			LIMIT			Note		
VISUAL DEFECT	INTERNAL	SPOT	$\varphi < 0.15\text{mm}$		Ignore	Note1		
			$0.15\text{mm} \leq \varphi \leq 0.5\text{mm}$		$N \leq 4$			
			$0.5\text{mm} < \varphi$		$N=0$			
		FIBER	$0.03\text{mm} < W \leq 0.1\text{mm}, L \leq 5\text{mm}$		$N \leq 3$	Note1		
			$1.0\text{mm} < W, 1.5\text{mm} < L$		$N=0$			
		POLARIZER BUBBLE	$\varphi < 0.15\text{mm}$		Ignore	Note1		
	$0.15\text{mm} \leq \varphi \leq 0.5\text{mm}$		$N \leq 2$					
	$0.5\text{mm} < \varphi$		$N=0$					
	Mura	It' OK if mura is slight visible through 6%ND filter						
	ELECTRICAL DEFECT	BRIGHT DOT	A Grade			B Grade		
C Area			O Area	Total	C Area	O Area	Total	Note3
$N \leq 0$			$N \leq 2$	$N \leq 2$	$N \leq 2$	$N \leq 3$	$N \leq 5$	Note2
DARK DOT		$N \leq 2$	$N \leq 3$	$N \leq 3$	$N \leq 3$	$N \leq 5$	$N \leq 8$	
TOTAL DOT		$N \leq 4$			$N \leq 5$	$N \leq 6$	$N \leq 8$	Note2
TWO ADJACENT DOT		$N \leq 0$	$N \leq 1$ pair	$N \leq 1$ pair	$N \leq 1$ pair	$N \leq 1$ pair	$N \leq 1$ pair	Note4
THREE OR MORE ADJACENT DOT		NOT ALLOWED						
LINE DEFECT		NOT ALLOWED						

(1) One pixel consists of 3 sub-pixels, including R,G, and B dot.(Sub-pixel = Dot)

(2) LITTLE BRIGHT DOT ACCEPTITABLE UNDER 6 % ND-Filter

[Note1] W : Width[mm], L : Length[mm], N : Number,  $\varphi$  : Average Diameter

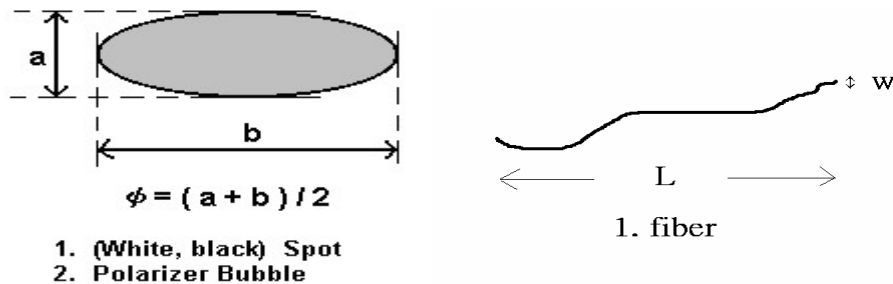

[Note2] Bright dot is defined through 6% transmission ND Filter as following.

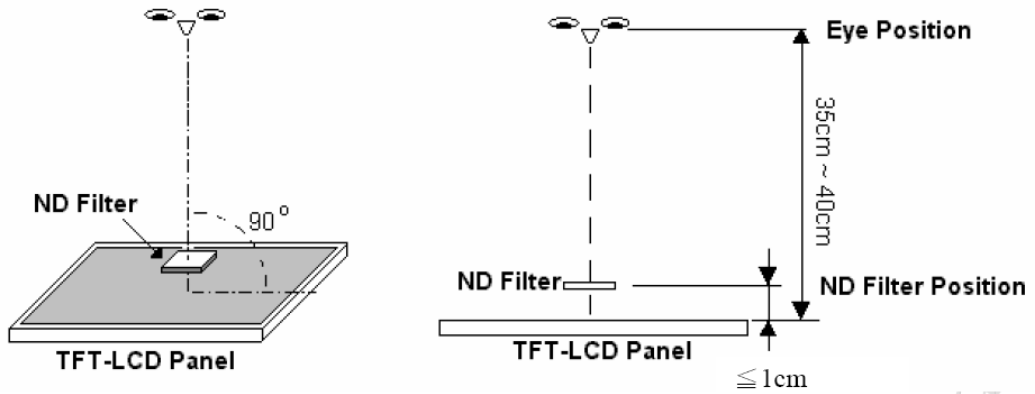

[Note3]

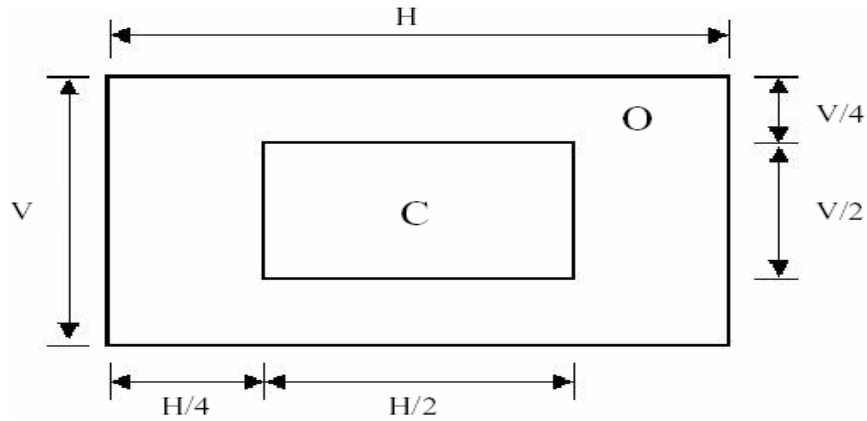

**C Area: Center of display area**

**O Area: Outer of display area**

[Note4]

Judge defect dot and adjacent dot as following. Allow below (as A, B, C and D status) adjacent defect dots, including bright and dark adjacent dot. And they will be counted 2 defect dots in total quantity.

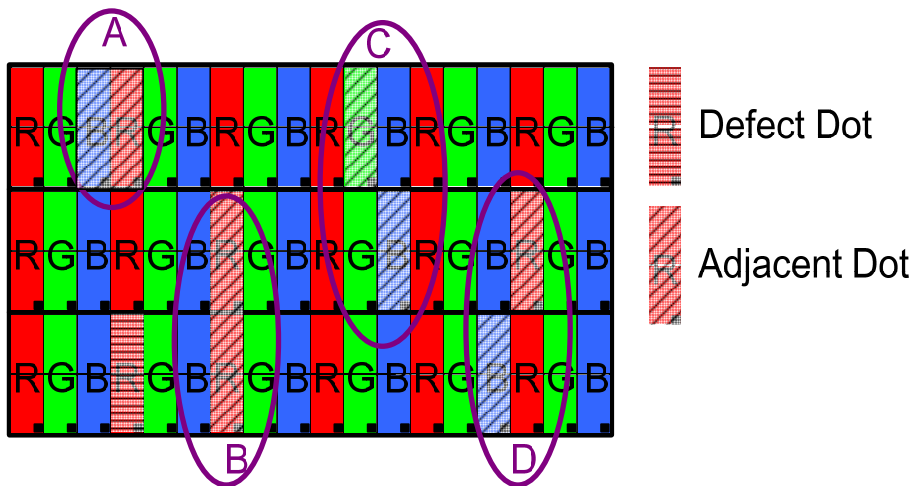

(1) The defects that are not defined above and considered to be problem shall be reviewed and discussed by both parties.

(2) Defects on the Black Matrix, out of Display area, are not considered as a defect or counted.

## 10. RELIABILITY TEST CONDITIONS

ITEM	CONDITIONS
HIGH TEMPERATURE OPERATION	70°C , 240Hrs
HIGH TEMPERATURE AND HIGH HUMIDITY OPERATION	60°C , 90%RH , 240Hrs
HIGH TEMPERATURE STORAGE	80°C , 240Hrs
LOW TEMPERATURE OPERATION	-20°C , 240Hrs
LOW TEMPERATURE STORAGE	-30°C , 240Hrs
THERMAL SHOCK	-30°C (0.5Hr) ~80°C (0.5Hr) 200Cycle

### 10.1 OTHERS

AMIPRE will provide one year warranty for all products and three months warrantee for all repairing products.



