

AZ2501

50 AMP LATCHING POWER RELAY

FEATURES

- 50 Amp switching
- Heavy loads to 13850 VA
- 4 kV dielectric strength
- 8 mm creepage distance
- Manual switch available
- Epoxy sealed version available
- UL, CUR file E44211



CONTACTS

Arrangement	SPST (1 Form A), SPDT (1 Form C)
Ratings	Resistive load: Max. switched power: 13850 VA Max. switched current: 50 A Max. switched voltage: 440 VAC
UL/CUR	1 Form A (SPST) 50 A at 277 VAC, resistive, 70°C, 100k cycles 5000 W at 240 VAC, Tungsten, 30k cycles 1 Form C (SPDT) 40 A at 277 VAC, General Use, 70°C, 30k cycles
Material	Silver tin oxide
Resistance	< 50 milliohms initially

COIL

Power	
At Pickup Voltage (typical)	.96 W single coil 1.9 W dual coil
Temperature	Max. 105°C (221°F)

NOTES

1. All values at 20°C (68°F).
2. Relay may pull in with less than "Must Operate" value.
3. Specifications subject to change without notice.
4. Initial state of contacts may be changed during transportation or shock!

GENERAL DATA

Life Expectancy Mechanical Electrical	Minimum operations 1 x 10 ⁶ 1 x 10 ⁵ at 50 A 250 VAC Res. (SPST)
Set and Reset Pulse Duration	50 ms minimum at nominal coil voltage
Set Time (typical)	15 ms at nominal coil voltage
Reset Time (typical)	15 ms at nominal coil voltage
Dielectric Strength (at sea level for 1 min.)	4000 Vrms coil to contact 1500 Vrms between open contacts
Insulation Resistance	1000 megohms min. at 20°C, 500 VDC, 50% RH
Creepage Distance	8 mm (1 Form A), 6 mm (1 Form C)
Ambient Temperature Operating Storage	At nominal coil voltage -40°C (-40°F) to 70°C (158°F) -40°C (-40°F) to 105°C (221°F)
Vibration	1.5mm DA at 10–55 Hz
Shock Operating Non-Operating	10 g, 11 ms, 1/2 sine (no false operation) 100 g, 11 ms, 1/2 sine (no damage)
Enclosure	P.B.T. polyester
Terminals	Tinned copper alloy
Max. Solder Temp.	270°C (518°F)
Max. Solder Time	5 seconds
Weight	32 grams

ZETTLER electronics GmbH

Junkersstrasse 3, D-82178 Puchheim, Germany

Tel. +49 89 800 97 0
Fax +49 89 800 97 200

office@ZETTLERelectronics.com
www.ZETTLERelectronics.com

2010-12-17

AZ2501

RELAY ORDERING DATA

COIL SPECIFICATIONS - STANDARD SINGLE COIL					
Nominal Coil VDC	Must Operate VDC	Max. Continuous VDC [1]	Coil Resistance Ohm $\pm 10\%$	ORDER NUMBER*	
				1 Form A	1 Form C
6	4.8	7.8	24	AZ2501P1-1A-6D	AZ2501P1-1C-6D
9	7.2	11.7	54	AZ2501P1-1A-9D	AZ2501P1-1C-9D
12	9.6	15.6	96	AZ2501P1-1A-12D	AZ2501P1-1C-12D
24	19.2	31.2	384	AZ2501P1-1A-24D	AZ2501P1-1C-24D
48	38.4	62.4	1536	AZ2501P1-1A-48D	AZ2501P1-1C-48D

COIL SPECIFICATIONS - STANDARD DUAL COIL					
Nominal Coil VDC	Must Operate VDC	Max. Continuous VDC [1]	Coil Resistance Ohm $\pm 10\%$	ORDER NUMBER*	
				1 Form A	1 Form C
6	4.8	7.8	12	AZ2501P2-1A-6D	AZ2501P2-1C-6D
9	7.2	11.7	27	AZ2501P2-1A-9D	AZ2501P2-1C-9D
12	9.6	15.6	48	AZ2501P2-1A-12D	AZ2501P2-1C-12D
24	19.2	31.2	192	AZ2501P2-1A-24D	AZ2501P2-1C-24D
48	38.4	62.4	768	AZ2501P2-1A-48D	AZ2501P2-1C-48D

* For epoxy sealed version (not allowed with manual switch) add suffix "E".

For manual switch add suffix "W".

For PCB retaining stud add suffix "K".

For reverse polarity coil add suffix "R".

NOTE: [1] Max. continuous voltage should not be applied for more than 60 seconds.

MECHANICAL DATA

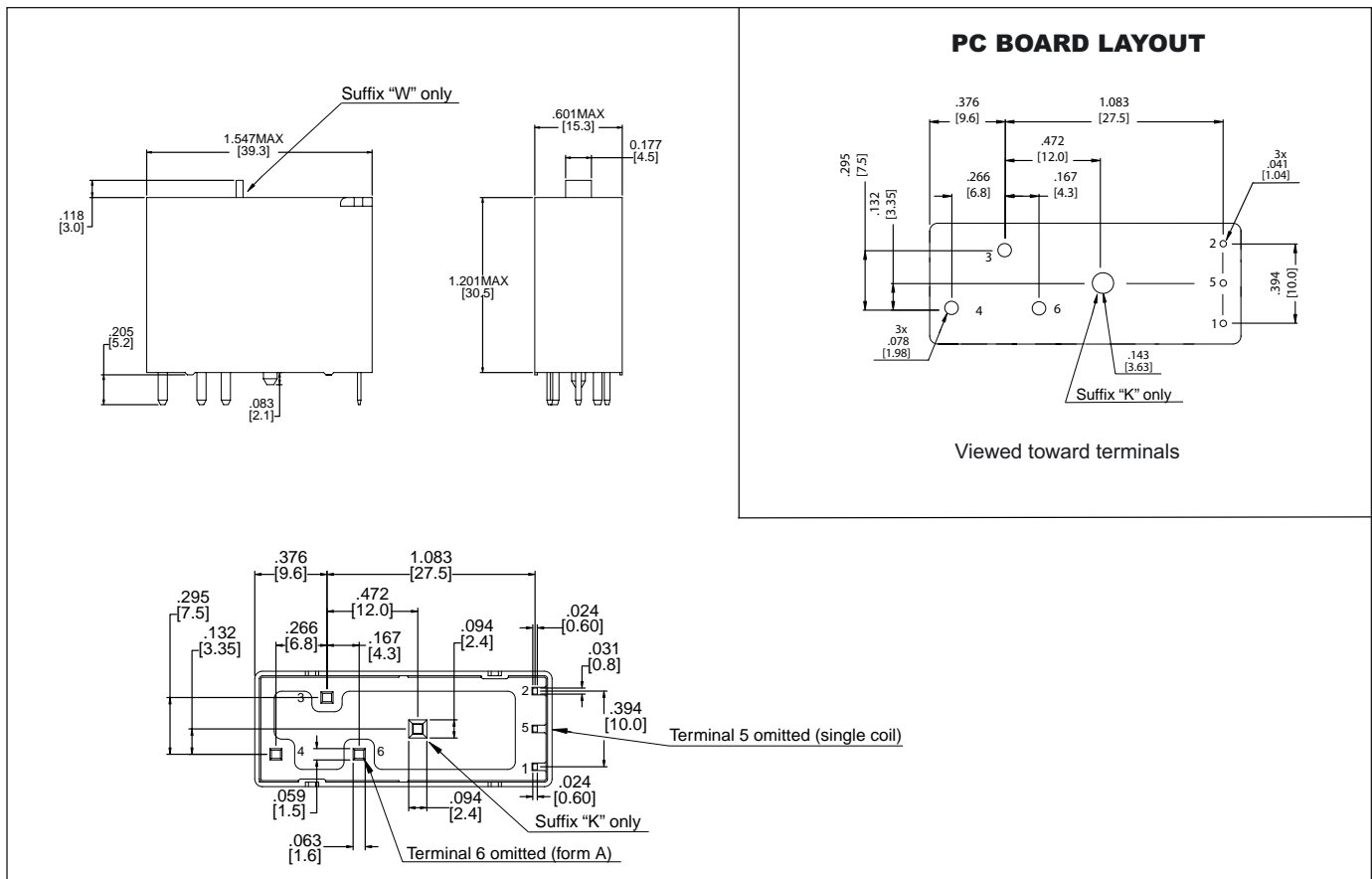

Dimensions in inches with metric equivalents in parentheses. Tolerance: $\pm .010$ "

ZETTLER electronics GmbH

Junkersstrasse 3, D-82178 Puchheim, Germany

Tel. +49 89 800 97 0

Fax +49 89 800 97 200

office@ZETTLERelectronics.com

www.ZETTLERelectronics.com

2010-12-17

AZ2501

WIRING DIAGRAMS

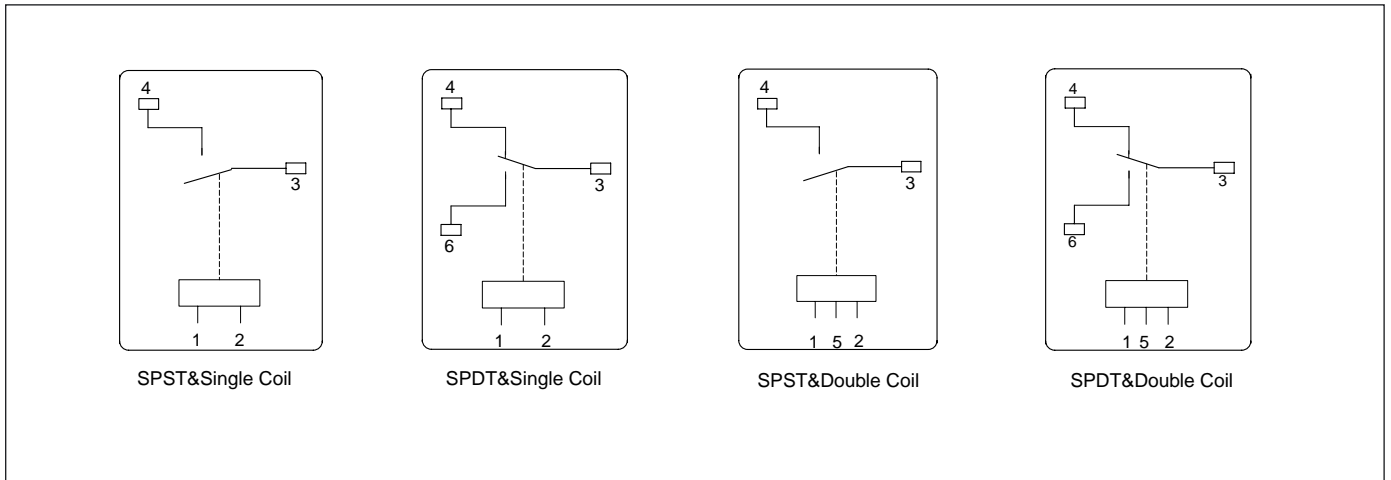

NOTE:

Standard Polarity type:

1. "Single Coil Latching Version"

- (1) After energizing 1 (+) and 2 (-), 50ms pulse, terminal 3 and 4 is connected.
- (2) After energizing 2 (+) and 1 (-), 50ms pulse, terminal 3 and 4 is disconnected.

2. "Double Coil Latching Version"

- (1) After energizing 5 (+) and 1 (-), 50ms pulse, terminal 3 and 4 is connected.
- (2) After energizing 5 (+) and 2 (-), 50ms pulse, terminal 3 and 4 is disconnected.

Reverse Polarity type:

1. "Single Coil Latching Version"

- (1) After energizing 1 (-) and 2 (+), 50ms pulse, terminal 3 and 4 is connected.
- (2) After energizing 1 (+) and 2 (-), 50ms pulse, terminal 3 and 4 is disconnected.

2. "Double Coil Latching Version"

- (1) After energizing 5 (-) and 1 (+), 50ms pulse, terminal 3 and 4 is connected.
- (2) After energizing 5 (-) and 2 (+), 50ms pulse, terminal 3 and 4 is disconnected.

ZETTLER electronics GmbH

Junkersstrasse 3, D-82178 Puchheim, Germany

Tel. +49 89 800 97 0
Fax +49 89 800 97 200

office@ZETTLERelectronics.com
www.ZETTLERelectronics.com

2010-12-17