

SUBMINIATURE POLARIZED POWER RELAY

FEATURES

- 8 A / 5 A switching capability
- 1 Form A, 2 Form A and combined 1 Form A / 1 Form B contact arrangements
- Monostable non-latching and bistable latching types available
- Single and dual coil latching versions
- Low coil power
- High Dielectric strength 3 kVAC
- Low height 10.5 mm
- Epoxy sealed versions optional, Gold plating optional
- UL Class F insulation (155°C) standard
- RoHS compliant
- UL, CUR file E44211

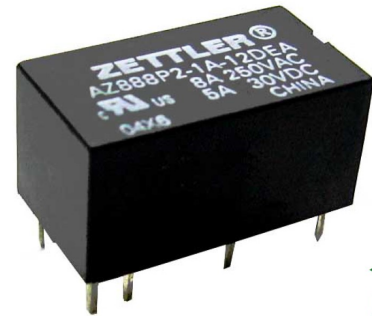

Illustration similar

CONTACTS

Arrangement	SPST-N.O. (1 Form A) DPST-N.O. (2 Form A) SPST-N.O. (1 Form A) / SPST-N.C. (1 Form B)
Ratings (max.) 1 Form A switched power switched current switched voltage	(resistive load) 150 W or 2000 VA 8 A 240 VDC* or 380 VAC
2 Form A 1 Form A/1 Form B switched power switched current switched voltage	150 W or 1250 VA 5 A 240 VDC* or 380 VAC * Note: If switching voltage is greater than 30 VDC, special precautions must be taken. Please contact the factory.
Contact materials	AgSnO ₂ - silver tin oxide gold plating available
Initial resistance	< 50 mΩ (1 A / 6 VDC, with gold plating: 0.1 A / 6 VDC)

COIL

Nominal coil DC voltages	see coil voltage specifications tables
Dropout voltage non-latching types	> 10% of nominal coil voltage
Coil power non-latching, dual coil latching at nominal voltage at pickup voltage	(typ. at 23°C) 300 mW 192 mW
single coil latching at nominal voltage at pickup voltage	150 mW 96 mW
Max. temperature	155°C (311°F), Class F

GENERAL DATA

Life Expectancy mechanical electrical	(minimum operations) 1 x 10 ⁷ 1 x 10 ⁵ at 8 A 250 VAC resistive (1s on/9s off) 3 x 10 ⁴ at 5 A 250 VAC resistive (2s on/2s off)
Operate Time non-latching types	at nominal coil voltage 10 ms (max.)
Release Time non-latching types	at nominal coil voltage, w/o coil suppression 5 ms (max.)
Set Time latching types	at nominal coil voltage 10 ms (max.)
Reset Time latching types	at nominal coil voltage 10 ms (max.)
Dielectric Strength	(at sea level for 1 min.) 3 kVAC coil to contacts 2 kVAC between contact sets 1 kVAC between open contacts
Surge voltage coil to contact	5 kV (at 1.2/50 μs)
Insulation Resistance	1000 MΩ (min.) at 23°C, 500 VDC, 50% RH
Temperature Range operating	(at nominal coil voltage) -40°C (-40°F) to 85°C (185°F)
Vibration resistance operating damage	2.0 mm (0.079") DA at 10–55 Hz 3.5 mm (0.138") DA at 10–55 Hz
Shock operating damage	20 g 100 g
Terminals	Tinned copper alloy, P. C.
Soldering max. temperature max. time	260°C (500°F) 5 seconds
Cleaning max. solvent temp. max. immersion time	80°C (176°F) 30 seconds
Dimensions length width height	20.2 mm (0.795") 11.3 mm (0.445") 10.5 mm (0.413")
Weight	4.5 grams (approx.)
Compliance	UL 508, RoHS, REACH

AZ888

UL/CUR APPROVED CONTACT RATINGS

1 Form A	8 A at 250 VAC, general use, 30k cycles, 85°C 8 A at 250 VAC, resistive, 50k cycles, 85°C * 8 A at 250 VAC, resistive, 100k cycles, 70°C 5 A at 30 VDC, resistive, 100k cycles, 70°C 5 A at 30 VDC, general use, 50k cycles, 85°C * 5 A at 30 VDC, general use, 30k cycles, 85°C 1/6 HP at 125/250 VAC, 6k cycles, 85°C B300 pilot duty, 30k cycles, 85°C R150 pilot duty, 30k cycles, 85°C B300 pilot duty, 50k cycles, 70°C R300 pilot duty, 50k cycles, 70°C 600 W tungsten, 220 VAC, 6k cycles, 70°C
2 Form A	5 A at 250 VAC, general use, 50k cycles, 40°C 5 A at 250 VAC, general use, 30k cycles, 85°C 5 A at 250 VAC, resistive, 100k cycles, 70°C 5 A at 30 VDC, resistive, 100k cycles, 70°C 5 A at 30 VDC, resistive, 30k cycles, 85°C 1/10 HP at 125/250 VAC, 6k cycles, 40°C B300 pilot duty, 50k cycles, 40°C R150 pilot duty, 50k cycles, 40°C
1 Form A/1 Form B	5 A at 250 VAC, general use, 50k cycles, 40°C 5 A at 250 VAC, general use, 30k cycles, 85°C 5 A at 250 VAC, resistive, 100k cycles, 70°C 5 A at 30 VDC, resistive, 100k cycles, 70°C 5 A at 30 VDC, resistive, 30k cycles, 85°C 1/6 HP at 125/250 VAC, 6k cycles, 40°C B300 pilot duty, 50k cycles, 70°C R150 pilot duty, 50k cycles, 70°C

* Note: For dual coil latching type only

ORDERING DATA

AZ888 - - D

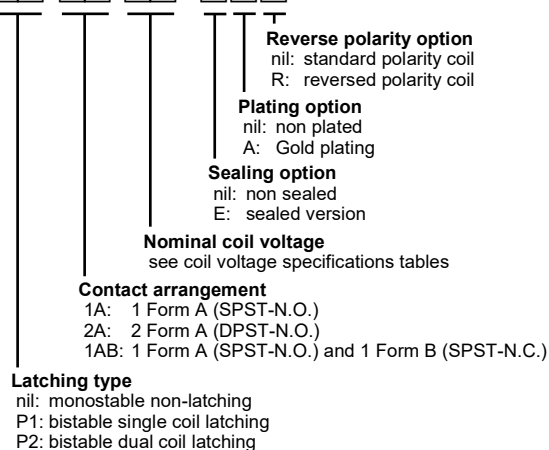

Example ordering data

AZ888-1A-5D	Monostable type, 1 Form A, 5 VDC nominal coil voltage, non sealed, non gold plated, standard coil polarity
AZ888P1-1AB-12DEA	Single coil latching, combined 1 Form A and 1 Form B contact arrangement, 12 VDC nominal coil voltage, sealed, gold plated, standard coil polarity
AZ888P2-2A-9DR	Dual coil latching, 2 Form A, 9 VDC nominal coil voltage, non sealed, non gold plated, reversed coil polarity

COIL VOLTAGE SPECIFICATIONS

Monostable non-latching

Nominal Coil VDC	Must Operate VDC	Max. Continuous VDC	Resistance Ohm ± 10%
3	2.4	3.9	30
5	4.0	6.5	83
6	4.8	7.8	120
9	7.2	11.7	270
12	9.6	15.6	480
18	14.4	23.4	1080
24	19.2	31.2	1920

Single coil latching

Nominal Coil VDC	Must Operate VDC	Max. Continuous VDC	Resistance Ohm ± 10%
3	2.4	3.9	60
5	4.0	6.5	167
6	4.8	7.8	240
9	7.2	11.7	540
12	9.6	15.6	960
18	14.4	23.4	2160
24	19.2	31.2	3840

Dual coil latching

Nominal Coil VDC	Must Operate VDC	Max. Continuous VDC	Resistance Ohm ± 10%
3	2.4	3.9	30
5	4.0	6.5	83
6	4.8	7.8	120
9	7.2	11.7	270
12	9.6	15.6	480
18	14.4	23.4	1080
24	19.2	31.2	1920

Note: All values at 23°C (73°F), upright position, terminals downward.

AZ888

MECHANICAL DATA

Dimensions in mm. Outline dimensions tolerance: $\pm 0.5\text{mm}$ unless stated otherwise. Pin dimensions given without tin coating.

Monostable non-latching and single coil bistable latching types

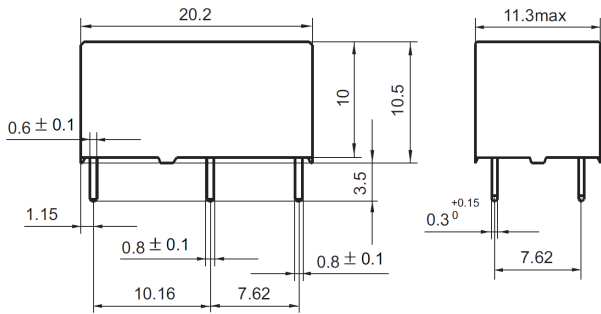

Bistable dual coil latching type

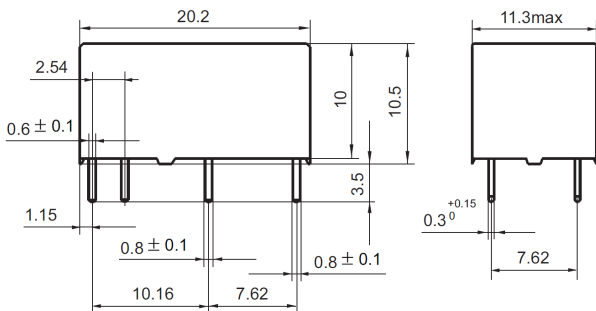

PC BOARD LAYOUT

Layout recommendation. Viewed towards terminals. Dimensions in inches with metric equivalents in parentheses.

Monostable non-latching and single coil bistable latching types

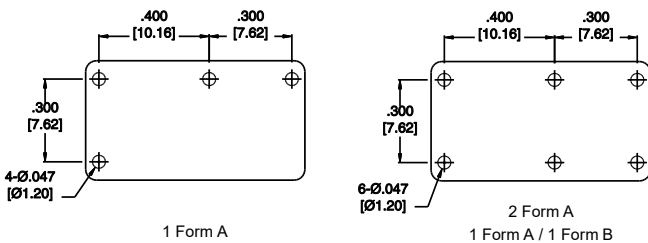

Bistable dual coil latching type

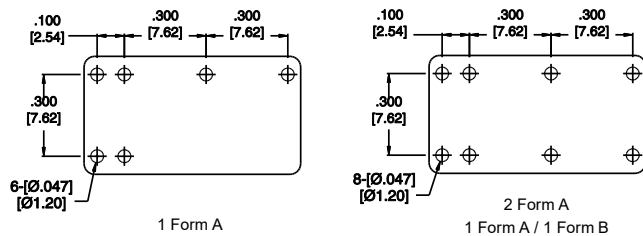

WIRING DIAGRAMS

Viewed towards terminals, shown in deenergized / reset condition.

Note: The diagrams show the standard coil polarity. The polarity is reversed for types with reverse polarity option 'R'.

Monostable non-latching type

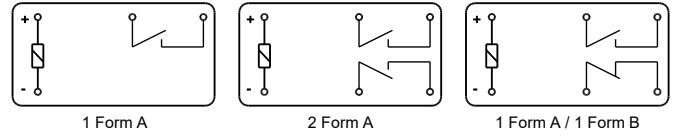

Bistable single coil latching type

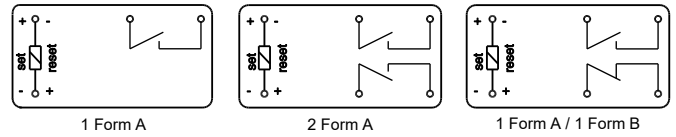

Bistable dual coil latching type

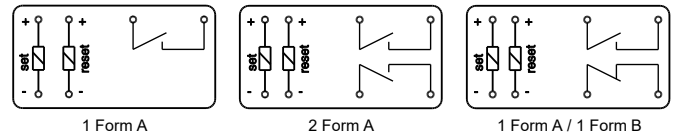

NOTES

1. All values at reference temperature of 23°C (73°F) unless stated otherwise.
2. Relay has a fixed coil polarity.
3. Keep away from strong magnetic fields to avoid alterations of "Must Operate voltage".
4. For isolation between the relay's magnetic fields, it is recommended that at least a .2" (5.0 mm) space is provided between adjacent relays.
5. Relay may pull in or set/reset with less than "Must Operate" value.
6. "Max. Continuous Voltage" is the maximum voltage the coil can endure for a short period of time.
7. For monostable non-latching types: Coil suppression circuits such as diodes, etc. in parallel to the coil will lengthen the release time.
8. For bistable latching types: Initial state of contacts may be changed during transportation or shock.
9. For bistable latching types: Recommended set / reset pulse width is 50 ms to 100 ms.
10. For dual coil latching types: Do not power set and reset coils simultaneously.
11. The minimum load values are for reference only. The part's suitability has to be confirmed in the application.
12. Relay adjustment may be affected if excessive shock is applied to the relay.
13. Relay adjustment may be affected if excessive pressure is exerted on the relay case.
14. Specifications subject to change without notice.

AZ888

DISCLAIMER

This product specification is to be used in conjunction with the application notes which can be downloaded from the regional ZETTLER relay websites. The specification provides an overview of the most significant part features. Any individual applications and operating conditions are not taken into consideration. It is recommended to test the product under application conditions. Responsibility for the application remains with the customer. Proper operation and service life cannot be guaranteed if the part is operated outside the specified limits.

ZETTLER GROUP

Building on a foundation of more than a century of expertise in German precision engineering, ZETTLER Group is a world-class enterprise, engaged in the design, manufacturing, sales and distribution of electronic components. Our industry leadership is based on a unique combination of engineering competence and global scale.

For more information on other ZETTLER Group companies, please visit zettler-group.com. For support on this product or other ZETTLER relays, please visit one of the group sites below.

SITES FOR ZETTLER RELAYS

NORTH AMERICA

American Zettler, Inc.
www.azettler.com
sales@azettler.com

EUROPE

Zettler Electronics, GmbH
www.zettlerelectronics.com
office@zettlerelectronics.com

Zettler Electronics, Poland
www.zettlerelectronics.pl
office@zettlerelectronics.pl

CHINA

Zettler Group, China
www.zettlercn.com
relay@zettlercn.com

ASIA PACIFIC

Zettler Electronics (HK) Ltd.
www.zettlerhk.com
sales@zettlerhk.com



ZETTLER